



General Description

The Rane AC 23S Active Crossover can be configured as a stereo 2- or 3-way, or a mono 4- or 5-way. It employs 4th-order Linkwitz-Riley filter alignments to minimize phase difficulties in the critical crossover region. The AC 23S uses XLR connectors with active balanced Inputs and Outputs.

Simply put, a Linkwitz-Riley alignment is two cascaded 2nd-order Butterworth filters exhibiting identical phase characteristics on their low-pass and high-pass outputs. This characteristic guarantees in-phase outputs at all frequencies. In-phase outputs are mandatory for proper acoustic summing of common signals from adjacent drivers in the crossover region. An added benefit of this topology is steep 24 dB per octave rolloff slopes. A slope of this magnitude guarantees drivers designed to produce a specific range of frequencies, and no more, will not be driven past their

limits, thereby minimizing distortion and driver fatigue.

To further guarantee the transparent operation of the AC 23S, adjustable Delay circuits appear on the Low & Mid Outputs of each Channel to compensate for any physical misalignment of the drivers. Time correction ensures the mechanical phase alignment of adjacent drivers will be acoustically correct, thus maintaining the integrity of the electrical phase alignment of the crossover's filters.

In 2- or 3-way stereo mode, the low outputs may be mono'ed by moving an internal jumper. Constant directivity (CD) horn equalization is possible with an internal modification. See the manual for details.

See the RaneNote *Linkwitz-Riley Crossovers* for more information, available at www.rane.com.

Features

- Stereo 2- or 3-Way, Mono 4- or 5-Way
- Linkwitz-Riley Alignment with 24 dB per Octave Slopes
- Adjustable Delays
- Infrasonic, Ultrasonic and RFI Filters
- Low & Mid Output Muting (3-Way)
- Input & Output Level Controls
- Fully Active Balanced XLR Inputs & Outputs
- Internal Universal Power Supply (100-240 VAC)



Features and Specifications

Parameter	Specification	Limit	Units	Conditions/Comments
Crossover: Alignment	Linkwitz-Riley			Proprietary 4th-order state-variable
.....Slopes	24 dB per Octave			
.....Range (3-way)	70-1 kHz Low to Mid			41-detent continuously variable pot
.....Range (3-way)	190-7 kHz Mid to High			as above
.....Range (2-way)	190-7 kHz Low to High			as above
Time Delay Adjust Range	Off to +2	5%	ms	Low & Mid Outputs only
Inputs: Impedance	20k	1	Ω	
.....Maximum Level	+21	1	dBu	
.....Gain Range	Off to +6	-0/+4	dB	
Inputs: Type	Active Balanced XLR			Pin 2 hot per AES standards
Outputs: Type	Active Balanced XLR			Pin 2 hot per AES standards
.....Impedance	200	1%	Ω	
.....Maximum Level	+20	1	dBu	600 Ω or greater
.....Gain Range	Off to +12	-0/+4	dB	
Band Muting Switches	Yes			Low & Mid Outputs only
RFI Filters	Yes			
Infrasonic Filter	20 Hz, 18 dB/Oct, Butterworth	3%	Hz	
Ultrasonic Filter	40 kHz, 18 dB/Oct, Bessel	3%	Hz	Linear phase
Frequency Response	20-40 kHz	+0/-3	dB	
THD+Noise	0.02	.01	%	+4 dBu, 20-20 kHz
IM Distortion (SMPTE)	0.02	.01	%	60 Hz / 7 kHz, 4:1, +4 dBu
Signal-to-Noise Ratio	92	2	dB	re +4 dBu, 20 kHz noise bandwidth
Maximum Power	7		W	
Universal Line Voltage	100-240 VAC, 50/60 Hz		VAC	7W
Unit: Agency Listing	UL/cUL/CE			
Unit: Construction	All Steel			
.....Size	1.75" H x 19" W x 5.3" D (1U)			(4.4 cm x 48.3 cm x 13.3 cm)
.....Weight	5 lb			(2.3 kg)
Shipping: Size	4.25" x 20.3" x 13.75"			(11.5 cm x 52 cm x 35 cm)
.....Weight	9 lb			(4.1 kg)
<i>Note: 0 dBu=0.775 Vrms</i>				

Block Diagram

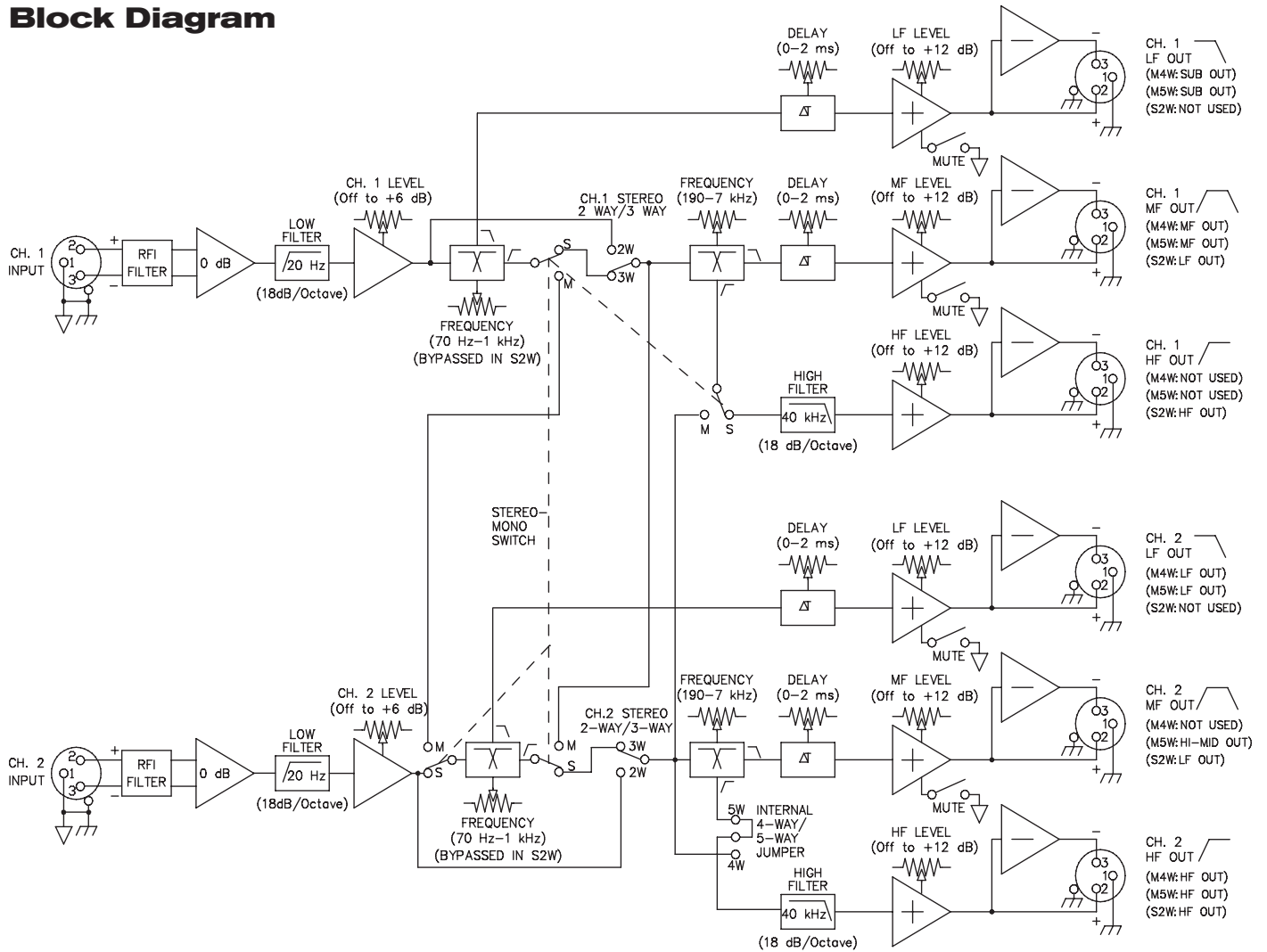

Rear Panel



Choosing the Right Configuration: Mono, Dual Mono, or Stereo?

Very few systems indeed will utilize a two channel crossover for the purpose of true stereo imaging. Discrete stereo channels which are run from the mixing board are usually used for panning effects and/or for separate equalization of left and right speaker stacks. Different sides of the room often require significantly different equalization due to varying room acoustics, dimensions, positioning of speaker stacks near walls, curtains and the like.

Even though you may not plan to use stereo equalization or panning effects, it is recommended that your system utilize discrete crossover channels for each stack of speakers to ensure flexibility and control for consistent, optimum sound quality. For example, if you plan to run a multi-stack system mono three-way, use the AC 23S rather than the AC 22S for separate control over each set of speakers—especially since phase alignment may differ with each stack requiring separate time delay adjustments. Even with only a single system equalizer, the AC 23S can deliver the extra independent control which can make a difference in sound throughout the listening area. If all drivers are built into a single cabinet, or you are running bi-amped monitors, then the AC 22B is the one for you.

Architectural Specifications

The active crossover shall contain 4th-order Linkwitz-Riley filters. Provisions shall exist to correct for driver misalignment by adding time delay to the low and mid frequency outputs.

The crossover frequency shall be controlled by a continuously variable control with 41 detents to allow mechanical reference of crossover setting.

Signal inputs and outputs shall be of active balanced design terminated with XLR connectors. RFI, infrasonic, and ultrasonic filters shall be built-in.

The active crossover shall afford an input level range of Off to +6 dB. The output level controls shall afford a level range of from Off to +12 dB with muting capability on the low and mid frequency outputs. The crossover shall supply two independent channels.

The unit shall be capable of operation by means of its own built-in universal power supply operating at 100-240 VAC and meet CE requirements. The unit shall be UL and cUL listed. The unit shall be entirely constructed from cold-rolled steel.

The unit shall be a Rane Corporation AC 23S Active Crossover.

Available Accessories

- SC 1.7 Security Cover

References

1. S.H. Linkwitz, "Active Crossover Networks for Noncoincident Drivers," *J. Audio Eng. Soc.*, vol. 24, pp. 2-8 (Jan/Feb 1976).
2. D. Bohn, "A Fourth-Order State-Variable Filter for Linkwitz-Riley Active Crossover Designs," presented at the 74th Convention of the Audio Engineering Society, New York, Oct. 9-12, 1983, preprint no. 2011.
3. D. Bohn, "Linkwitz-Riley Crossovers: A Primer," *RaneNote*, (1983, 1989, 2005).
4. D. Bohn, "Why Not Wye?" *RaneNote*, (1984).