



**General Description**

The Rane AM2 is both an 8 channel, gain-sharing automatic mic mixer and simultaneously a Rane RAD. Use it as a standalone mic-only mixer, or add more gain-shared mics using up to seven additional AM2 Automixers. Use the RAD Port to transport the main mix digitally via CAT 5 to either a Rane HAL's RAD Port, or to a Rane Mongoose to a CobraNet network. If you would also like manually mixed line audio sources, including USB Audio I/O, see the Rane AM1 Automixer.

Each of the eight XLR Mic Inputs offers front panel input Level controls feeding a gain-sharing automatic mixer. Rear panel, 3-position selectors support dynamic mics (no phantom power), condenser mics (48 V), or wireless receiver outputs (+12 dBV max). All Level controls come with front panel signal and overload indicators.

The AM2 is optimized for automixing speech. The mic inputs have a fixed 80 Hz to 7 kHz bandpass filter to provide the best voice-only automatic mixing using the gain-sharing algorithm.

The XLR Main Output can be set to mic- or line-level to feed a mic snake or a +20 dBu max balanced input. When an AM2 is used standalone, both the XLR Output and the RAD Port output audio are affected by the front panel Output Level control. When the AM2's Cascade Output feeds a downstream Rane AM1 or AM2, the front panel Output Level control only affects the XLR Output.

The USB port is solely used as a firmware update port if future updates are needed.

The RAD Port sends the AM2 output mix to either a Rane HAL's RAD Port for further signal processing and control, or to a Mongoose for routing to a CobraNet network. Cascade IN accepts audio and data from an upstream AM2's Cascade OUT. This adds eight more mic channels to the initial AM2 creating a 16-channel gain-sharing automix. A maximum of eight AM2s

can be cascaded, offering up to 64 gain-shared mics. If an AM1 is included, it must be the final device in the chain of no more than eight. Simply connect Cascade OUT ports to Cascade IN ports and the AM1 RAD Port to the Mongoose or HAL. Both the Cascade IN port and the Cascade OUT/RAD Port have status indicators to aid setup and troubleshooting.

Rear panel Fault, Locate, USB and Power indicators inform head-scratchers of device errors, the AM2's physical location, positive USB audio device OS registration and AC power status.

Duplicate Locate and Power indicators on the front help installers physically locate and verify AC power to the AM2.

Universal IEC power on the rear supports 100 to 240 VAC and 50/60 Hz.

**Features**

**INPUTS:**

- Gain-Sharing Automatic Mic Mixing:
  - 8 XLR Inputs with Level controls & Sig/OL indicators.
  - Select Mic, Mic with 48V phantom, or Line level.

**OUTPUT:**

- XLR Main with Mic/Line switch, Level control & Sig/OL.
- Rane RAD and Cascade IN RJ-45 Ports:
  - Cascade In Port connects up to seven Rane AM2 Automixers.
  - RAD Port sends Output to either HAL (DSP/control) or Mongoose (CobraNet).

**Rear Panel**



## Features and Specifications

<b>XLR Inputs</b>	Mono, Balanced, Mic/Line Selectable
Phantom Power	+48V per IEC 60268-15, Selectable in Mic mode
Maximum Input	-18 dBV / -6 dBv / +12 dBV (Dynamic / Condenser / Wireless)
Input Impedance	2.01k, 1%
Input Gain Range (Mic/Wireless)	-80 to +34 dB / -80 to +26 dB
Frequency Response	80 Hz to 7 kHz, +0/-3 dB, -20 dBFS, Extended vocal range
<b>Main Output</b>	Mono, Balanced, XLR
Maximum Output (Mic/Line)	-20 / +20 dBu, 10 kΩ load
Output Impedance (Mic/Line)	51 / 300 Ω, 1%
Output Gain Range	-80 to 0 dB
Frequency Response	80 Hz to 7 kHz, +0/-3 dB, -20 dBFS
Dynamic Range	101 dB re +20 dBu, 20 kHz BW, A-weighted, 0 dB gain, 10 kΩ load
THD+N	< 0.02%, 100 Hz to 7 kHz, A-weighted, +4 dBu, 0 dB gain, 10 kΩ load
<b>LED Meters</b>	Mono, peak detecting
Signal	-50 dBFS, Green LED, Peak-Reading
Overload	-0.5 dBFS, Red LED, Peak-Reading
<b>RAD / Cascade In / Out</b>	8P8C (RJ-45) Connector
Sample Rate and Resolution	48 kHz @ 24 bits
<b>Unit</b>	All Steel Construction
Universal Line Voltage	100 to 240 VAC, 50/60 Hz, 13 W
Conformity	CE, FCC, cCSAus
U.S. Patent No. 8,542,849	
Size	1U 1.75"H x 19"W x 8.5"D (4.4 cm x 48.3 cm x 21.6 cm)
Weight	5 lb 4 oz (2.4 kg)
Shipping Size	4.5" x 20.3" x 13.75" (11.5 cm x 52 cm x 35 cm)
Shipping Weight	9 lb (4.1 kg)
<i>Note: 0 dBu = 0.775 Vrms</i>	

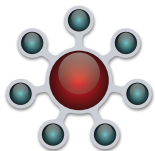

## HALOGEN

### AM2 use with HAL

The AM2 is a RAD allowing its manually-created mono mix to be sent digitally to a Rane HAL's RAD port via a CAT 5 cable. The Rane RADX supports doing so portably – with the AM2 in a padded rack or on a portable AV cart, for example. Once the AM2 mix is in the HAL, additional signal processing such as EQ and compression can be added. Control of the mix's level using Rane's DR1 or DR3 Digital Remotes is also possible.

The AM2 mixer also digitally cascades into Halogen's Gain-Sharing Auto Mixer or Room Combine Processor. This means the gain-sharing algorithm automatically treats AM2 microphones and any other microphone wired into these DSP blocks as being part of the same gain-share. This provides superior gain before feedback since all mics in the room, regardless of where and how

they are plugged in to the audio system, all work as one. This maintains your feedback stability margin.

To maintain PAG & NAG like you never have before, connect the AM2's Cascade Out jack with a shielded CAT 5e (or better) cable into any HAL RAD port. In Halogen software, in the Processing Workspace, drag the AM2 onto the Cascade In on either a Gain-Sharing Auto Mixer or a Room Combine Processor.

You can cascade as many AM2 mixers into these two DSP blocks as you have RAD Ports available. With a maximum of 36 total RAD ports in a full HAL1, and a maximum of 8 AM2s cascaded externally, over 2,000 channels are possible – yet not many systems require this many mics.

The AM1 lacks a Cascade Out port, so it cannot be cascaded into hardware (e.g., AM2) or software blocks in Halogen.

**Block Diagram**

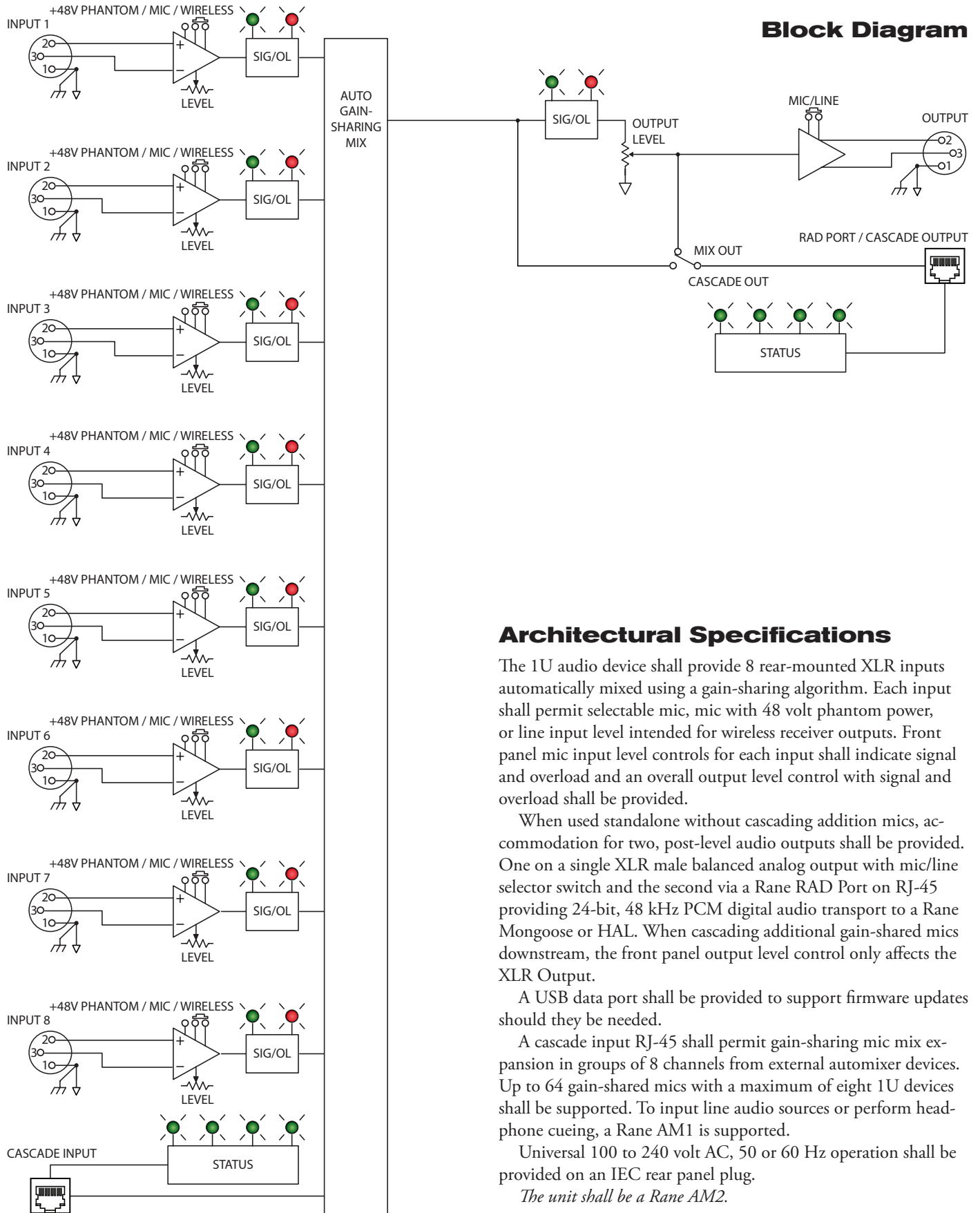

**Architectural Specifications**

The 1U audio device shall provide 8 rear-mounted XLR inputs automatically mixed using a gain-sharing algorithm. Each input shall permit selectable mic with 48 volt phantom power, or line input level intended for wireless receiver outputs. Front panel mic input level controls for each input shall indicate signal and overload and an overall output level control with signal and overload shall be provided.

When used standalone without cascading addition mics, accommodation for two, post-level audio outputs shall be provided. One on a single XLR male balanced analog output with mic/line selector switch and the second via a Rane RAD Port on RJ-45 providing 24-bit, 48 kHz PCM digital audio transport to a Rane Mongoose or HAL. When cascading additional gain-shared mics downstream, the front panel output level control only affects the XLR Output.

A USB data port shall be provided to support firmware updates should they be needed.

A cascade input RJ-45 shall permit gain-sharing mic mix expansion in groups of 8 channels from external automixer devices. Up to 64 gain-shared mics with a maximum of eight 1U devices shall be supported. To input line audio sources or perform head-phone cueing, a Rane AM1 is supported.

Universal 100 to 240 volt AC, 50 or 60 Hz operation shall be provided on an IEC rear panel plug.

*The unit shall be a Rane AM2.*

**Applications**

Facilities and rental agencies are called upon to provide either equipment, or equipment and operators, for meetings or conferences needing A/V support. The equipment providers must ensure audio quality throughout the event to get repeat business. However, the provided equipment may be operated by presenters who have no audio experience. If an operator is sent with the equipment to set up and manage the system during the presentation, that operator may have minimal audio experience. Pitfalls abound when interconnecting the system, and managing multi-microphone gain before feedback, mixing and volume. Enter the Rane AM2.

The AM2 makes it easy to quickly set up and manage multiple microphones for presentations involving up to eight participants with wired or wireless microphones. When cascading the AM2 with the AM1 (sold separately), support for several program audio sources (e.g., DVD, laptop, MP3 player) is easily added.

The AM2 offers a professional integrated solution providing superior automatic gain before feedback while eliminating operator error with its simple controls. The microphone gain-sharing algorithm automatically and appropriately attenuates mics not in use while maintaining the 3 dB per doubling of mics for different talkers (noncoherent signals), and 6 dB per doubling for the same talker who is directly between two mics (coherent signals).

**Record to or playback from your computer on USB.**

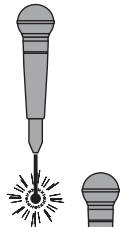
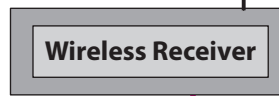
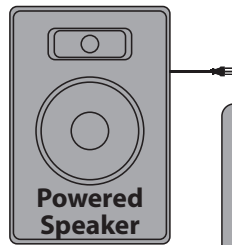
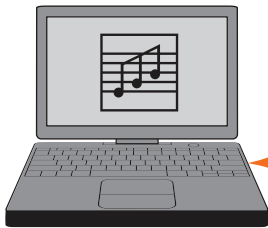

**AM1 Automixer**

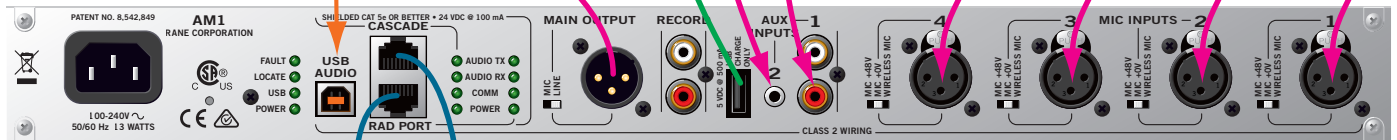

To HAL (optional)

**AM2 Automixer**



**Additional AM2s (up to seven)**

All additional mics will gain-share

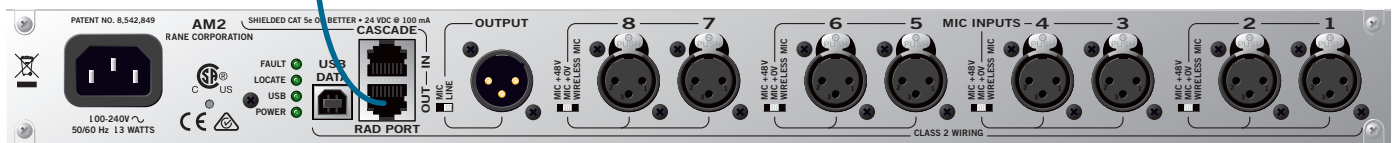

- USB cable
- Ethernet (CAT 5e)
- Audio cable