

General Description

A cure for compression confusion is here. Quit guessing and anguishing over proper compressor and gate settings. Get on with what is important, your work. Rane has created a compressor gate using high quality log rms detectors and Voltage Controlled Amplifiers (VCAs). The DC 22S combines quality compression and gate functions with simplicity. No more compression headache!

Lets start with what a compressor actually does. No matter how you cut it, this is an automatic volume control... a hand on a control, turning it down and turning it up again. The hand is fast and accurate, but it is just turning a volume control.

When the input signal reaches a level set by the Threshold control, the compressor begins to turn the signal down by an amount determined by the Ratio control. The DC 22S, like most compressors, operates by making the loud signals quieter, but does not make the quiet parts louder. However, by keeping the loud signals under control, the entire system may be turned up when necessary to make the quiet parts louder.

There is more than just a stereo compressor working here. The adjustable Gate is a downward expander, acting like a compressor running in reverse, making the quiet parts quieter. This is valuable in reducing system background noise. The Ratio is fixed at 2:1. When the signal drops below the set Threshold, the Gate Threshold indicator lights and the output level is reduced by 2 dB for every 1 dB the input signal level drops.

When using the DC 22S as a true stereo processor with left and right signals, activate the Link switch. In Link mode, channel 1 becomes the Master and channel 2 the Slave. Gate Threshold, Compression Threshold, Compression Ratio and Output Level are all controlled by channel 1. This ensures that both channels track perfectly, maintaining perfect balance and image. The channels are totally independent with the Link switch off.

The DC 22S offers performance and simplicity not found (until now) in this price range. Designed for the working musician or club system, The DC 22S provides reduced complexity without compromise in audio quality or dependability.

Features

- Two Independent Gates
- Two Independent Compressors
- Two Independent Output Level controls
- True Master / Slave operation in Link Mode
- -10 dBV / +4 dBu Input Sensitivity Switch
- +4 dBu and Overload Indicators
- Balanced XLR & ¼" TRS Connectors
- Internal Universal Power Supply (100-240 VAC)



Features and Specifications

Parameter	Specification	Limit	Units	Conditions/Comments
Gain	0 / +12	±0.2	dB	+4 dBu / -10 dBV sensitivity
Detector: Type	Log rms			
.....Response	80 dB per second			Fixed
Compressor:				
.....Threshold Range	+20 to -40	±2	dBu	
.....Ratio	1:1 to infinity:1	10%		
Gate:				
.....Threshold	-20 to -80	±2	dBu	
.....Ratio	2:1	10%		Fixed
Inputs:				
.....XLR	Active Balanced			Pin 2 "hot" per AES standards
.....¼" TRS	Active Balanced/Unbalanced			
.....Impedance	20k	1%	Ω	Common mode each leg to ground
.....Maximum Level	+22	1	dBu	
Outputs:				
.....XLR	Active Balanced			100 Ω impedance each leg
.....¼" TS	Active Unbalanced			300 Ω impedance
.....Maximum Level	+20	1	dBu	2k Ω
.....Gain Range	±15	±1.5	dB	
Frequency Response	20 Hz - 40 kHz	+0/-5	dB	R load > 2 kHz
THD+Noise	0.02	typ.	%	1 kHz @ +4 dBu
.....vs Amplitude	0.05	max.	%	0 to +20 dBu @ 1 kHz
.....vs Frequency	0.02	max.	%	+4 dBu, 20 Hz to 20 kHz
Signal-to-Noise Ratio	100	typ.	dBr	Unity gain, re +4 dBu, 20 kHz BW
Common Mode Rejection Ratio	40	min.	dB	
Universal Line Voltage	100-240 VAC, 50/60 Hz		VAC	7W
Unit: Agency Listing	UL/cUL/CE			
Unit: Construction	All Steel			
.....Size	1.75"H x 19"W x 5.3"D (1U)			(4.4 cm x 48.3 cm x 13.5 cm)
.....Weight	5 lb			(2.3 kg)
Shipping: Size	4.25" x 20.3" x 13.75"			(11 cm x 52 cm x 35 cm)
.....Weight	8 lb			(3.6 kg)

Note: 0 dBu = 0.775 Vrms

DC 22S Block Diagram

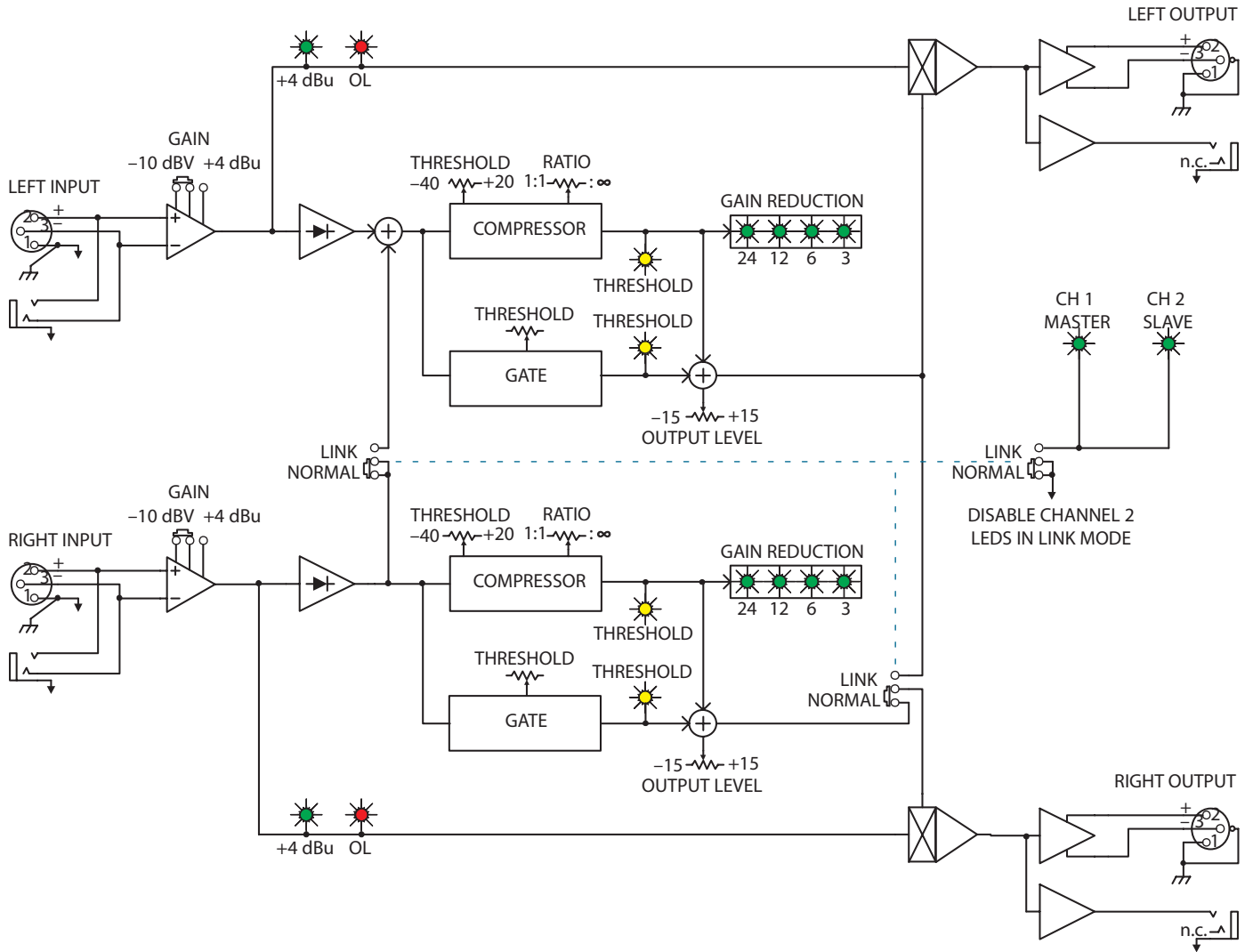

DC 22S Applications

- Two-Channel Compressor/Limiter and Gate
- Guitar & Bass Compression with Gate
- Post Production Dynamics Control
- Sound System with Compression and Gate
- Driver Protection
- Long Distance Line Driver

Reference

For details on what the DC 22S can do for your sound, see the RaneNote *Dynamics Processors — Technology & Application Tips* available at the Rane website.

Rear Panel**Architectural Specifications**

The Dynamic Processor shall be a two-channel unit with separate Gate Threshold, Compression Threshold, Compression Ratio and Output Level controls. A Link switch shall provide true Master / Slave operation of Gate, Compression and Output Level functions. Gate and compression threshold indicators shall be provided. A four-segment meter shall indicate compression gain-reduction for each channel.

The Compressors shall provide a threshold range of +20 dBu to -40 dBu and a ratio range of 1:1 to ∞ :1. The Gates shall operate with a threshold range of -20 dBu to -80 dBu with a fixed ratio of 2:1. The response time of the detector shall be 80 dB/second.

Each Input shall feature XLR and TRS connectors, active balanced input buffer, RFI filtering and -10 dBV / +4 dBu sensitivity switch. Input levels shall be monitored by +4 dBu and overload indicators. Each channel shall feature a bypass switch that disconnects the dynamics processing and connects the buffered input to the output amplifiers.

Each output shall feature XLR and TRS connectors, active balanced line drivers and RFI filtering.

The unit shall be capable of operation by means of its own built-in universal power supply operating at 100-240 VAC and meet CE requirements. The unit shall be UL and cUL listed. The unit shall be entirely constructed from cold-rolled steel. The unit shall occupy one rack space in height.

The unit shall be a Rane Corporation Model DC 22S.