



## General Description

The Rane HC6S is one of the most indispensable products in today's audio industry. Featuring six stereo headphone amplifiers, the HC6S performs a number of necessary tasks, not all of which are headphone related.

The HC6S provides Master stereo Inputs which can be used to drive any or all of the 6 stereo headphone amplifiers. A Mono switch is provided on the front panel to drive both channels of all 6 amplifiers from a common mono source. Six individual unbalanced stereo Inputs are available to drive any individual amplifier from a separate stereo source. These Inputs can be converted to mono balanced Inputs through internal jumpers if required. Outputs for all six channels are provided on the

front panel and on the rear panel so that headphones may be connected on either side based on the requirements of a given installation. Two pairs of headphones may be driven from each channel, one pair connected to the front and one to the rear.

The HC6S is capable of delivering up to 500 milliwatts into headphones with rated impedances between 32-600 ohms. The precise amount of power depends on the exact impedance of the headphone in use and the number of headphones connected to the unit. Under most conditions, the HC6S produces sound pressure levels in excess of 120 dB. This level is more than adequate for most listeners.

## Features

- Six Stereo Headphone Amplifiers
- Master Balanced/Unbalanced Stereo Inputs
- Six Unbalanced Stereo Inputs
- Six Output Level Controls
- Master Input Level Controls
- Stereo/Mono Switch
- Front and Rear Output Jacks
- Internal Universal Power Supply (100-240 VAC)



**HC6S Specifications**

Parameter	Specification	Limit	Units	Conditions/Comments
Power Output:	1 Channel Driven			Max average rms power, 20-20 kHz
	500	5%	mW	32 Ω headphones
	500	5%	mW	50 Ω headphones
	500	5%	mW	100 Ω headphones
	300	5%	mW	200 Ω headphones
	200	5%	mW	300 Ω headphones
	120	5%	mW	600 Ω headphones
	6 Channels Driven			
	250	5%	mW	32 Ω headphones
	250	5%	mW	50 Ω headphones
	250	5%	mW	100 Ω headphones
	200	5%	mW	200 Ω headphones
	100	5%	mW	300 Ω headphones
	120	5%	mW	600 Ω headphones
	(Note: Above values produce loudness levels of 120 dB in most headphones)			
Headphone Impedance Range	32-600	10%	Ω	For best performance
Inputs: Type	Active Balanced/Unbalanced			
.....Connectors	¼" TRS			
.....Impedance	20k	1%	Ω	
.....Maximum Level	+20	1	dBu	
Outputs: Type	(6) Stereo Amplifiers			(6) Outs front + (6) Outs rear
.....Connectors	¼" TRS			Tip = Left, Ring = Right
.....Impedance	0.25	typ.	Ω	Headphone Outputs
Overall Gain Range	Off to +20	1	dB	
LED Threshold: Signal Present	-20	1	dBu	Input Level
Ultrasonic Filter	20 kHz, 6 dB/octave	5%	Hz	Linear phase
Frequency Response	20-20 kHz	+0/-3	dB	
THD+Noise @ 1 kHz	0.002	.002	%	150 mW / 200 Ω, 1 channel
THD+Noise 20-20 kHz	0.02	.01	%	150 mW / 200 Ω, 1 channel
IM Distortion (SMPTE)	0.03	.01	%	60 Hz / 7 kHz, 4:1, 150 mW / 200 Ω
Signal-to-Noise Ratio	-96	2	dB	re 150 mW / 200 Ω, A-weighted
Mean Time Between Failure	20,500		Hrs	Mil Hdbk-217D, Section V
Universal Line Voltage	100-240 VAC, 50/60 Hz		VAC	12W
Maximum Power	12		W	
Unit: Conformity	CE, FCC, cULus			
Unit: Construction	All Steel			
.....Size	1.75"H x 19"W x 5.3"D (1U)			(4.4 cm x 48.3 cm x 13.5 cm)
.....Weight	5 lb			(1.9 kg)
Shipping: Size	4.25" x 20.3" x 13.75"			(11 cm x 52 cm x 35 cm)
.....Weight	9 lb			(4.1 kg)
<i>Note: 0 dBu = 0.775 Vrms</i>				

### Block Diagram

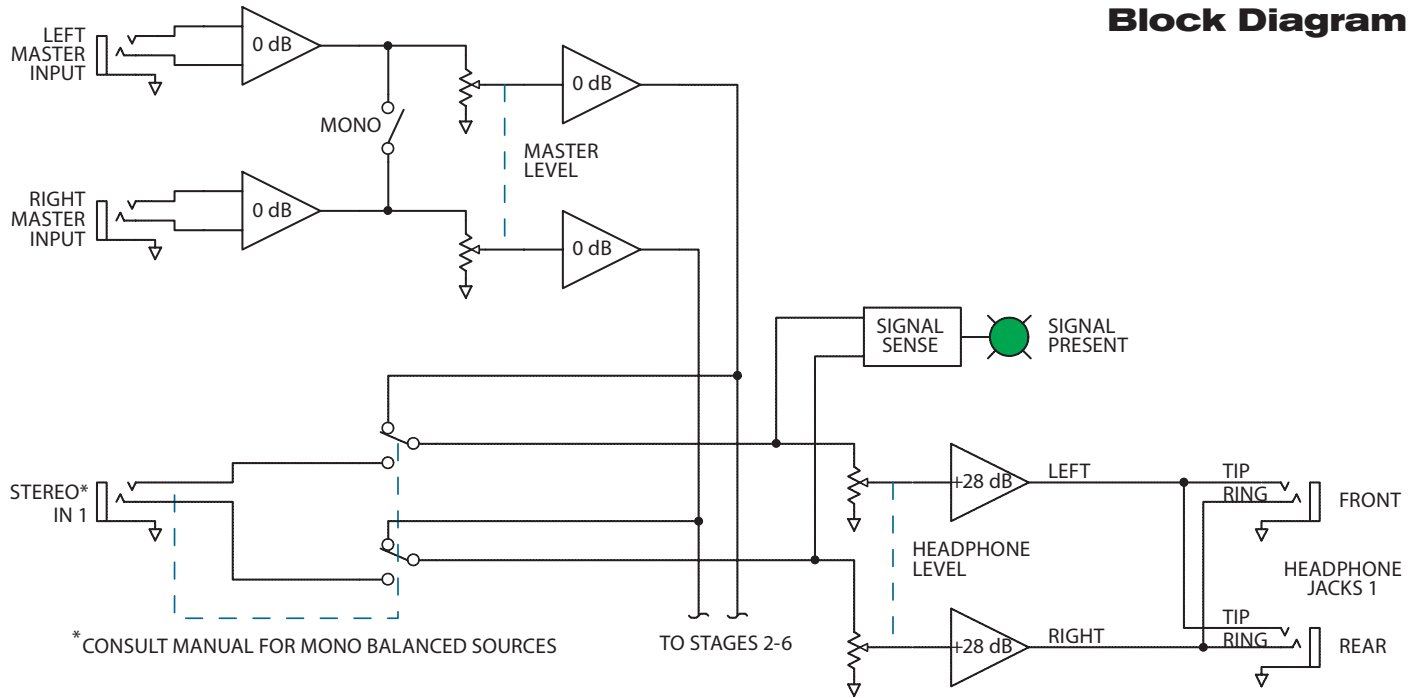

### Application Information

At first glance the HC6S looks like any other headphone distribution amplifier. Indeed, it performs superbly all the basic functions of such an instrument. Two balanced Inputs provide a master stereo signal to six stereo headphone amplifiers, with individual stereo Level controls. The Master Level allows adjustment of the main stereo Input level for proper matching to any source. In addition, a Stereo/Mono switch converts the stereo Inputs to mono operation when required.

However, several unique features of the HC6S allow performance well beyond the limits of standard headphone distribution amplifiers. Besides the stereo Master Inputs, the HC6S provides separate stereo Inputs for each of the six headphone amplifiers. Whenever a signal is plugged into the individual stereo Input, the Master stereo signal automatically disconnects from that amplifier, allowing the remaining stages to be fed either from the Master stereo Inputs or likewise from another separate input. This feature opens new applications for the HC6S, allowing operation as either a standard distribution amplifier or as six separate amplifiers, or any combination of both. By connecting the six Inputs to a monitor mixing console, or to sub-master sends, or even to a patch bay, the HC6S converts any size studio to a custom headphone monitor mixing system. You now can

give each vocalist more of their voice for increased clarity; or add more kick drum to the bassist (without giving everyone else a headache); or let the producer monitor the straight mix all at the same time. This feature proves equally valuable to broadcast facilities, video production studios, language labs and other educational facilities.

The HC6S provides Output jacks on both the front and rear panels. The front jacks (paralleled with the rear jacks) add considerable flexibility and ease of operation. This feature allows permanent rack-mounting while maintaining instant access to any of the Outputs. Cueing becomes a snap; a must for monitor mix adjustments, and allows additional monitoring or routing without the use of a patch bay. Or, for language labs and other demo purposes, this feature means up to 12 headphones may be driven simultaneously.

The HC6S makes a valuable tool for any band wanting to practice anywhere, anytime, at any volume, without disturbing a soul. By connecting the HC6S directly to the mixer outputs and using headphones instead of amps and speakers, the entire band can perform at ear shattering levels, with no feedback, with amazingly cleaner, clearer sound. The HC6S is a very cost-effective alternative to renting a practice studio for every rehearsal.

### Rear Panel



### Headphone Sensitivity

Headphone manufacturers specify a “sensitivity” rating for their products that is very similar to loudspeaker sensitivity ratings. For loudspeakers, the standard is to apply 1 watt and then measure the sound pressure level (SPL) at a distance of 1 meter. For headphones, the standard is to apply 1 milliwatt (1 mW = 1/1000 of a watt) and then measure the sound pressure level at the ear-piece (using a dummy head with built-in microphones). Sensitivity is then stated as the number of dB of actual sound level (SPL) produced by the headphones with 1 mW of input; headphone specifications commonly refer to this by the misleading term “dB/mW.” What they really mean is dB SPL for 1 mW input.

Think about these sensitivity definitions a moment: headphone sensitivity is rated using 1/1000 of a watt; loudspeaker sensitivity is rated using 1 watt. So a quick rule-of-thumb is that you are going to need about 1/1000 as much power to drive your headphones as to drive your loudspeakers since both of their sensitivity ratings are similar (around 90-110 dB SPL). For example, if your hi-fi amp is rated at 65 watts, then you would need only 65 mW to drive comparable headphones. (Actually you need less than 65 mW since most people don’t listen to their loudspeakers at 1 meter.) And this is exactly what you find in hi-fi receivers—their headphone jacks typically provide only 10-20 mW of output power.

Take another moment and think about all those phones and MP3 players. They sound great, and loud. Why, you can even hear them ten feet away as the teenage skateboarder that ran over your foot escapes.

Power output? About 12 mW.

### Architectural Specifications

The headphone console shall have six (6) stereo inputs and two (2) master inputs driving six (6) stereo amplifiers wired to six (6) outputs on the front panel, in parallel with six (6) outputs on the rear chassis. Sufficient output power shall be provided to drive most stereo headphones to levels of 120 dB SPL.

Automatic switching shall be included such that driving any of the separate inputs disconnects that one channel from the main stereo driving bus internally, allowing separate program material to be processed through the driven channel.

Input level controls shall be provided on all inputs with a gain range from off to +28 dB. A stereo/mono switch shall be located on the front panel.

The master inputs shall be active balanced/unbalanced designs terminated with ¼" TRS (tip-ring-sleeve) connectors. The outputs shall be ¼" TRS connectors wired tip-left, ring-right, sleeve-common.

Ultrasonic filters shall be built-in, and LEDs provided to indicate Signal Present conditions on all amplifier inputs.

The unit shall be capable of operation by means of its own built-in universal power supply operating at 100-240 VAC and meet CE requirements. The unit shall be UL and cUL listed. The unit shall be entirely constructed from cold-rolled steel.

*The unit shall be a Rane Corporation Model HC6S.*