



General Description

The MA 3 is a three-channel amplifier designed to operate reliably in commercial environments. The MA 3 was specifically designed for use in:

- Paging
- Foreground Music
- Background Music Distribution

and with Rane's paging, foreground music, and background music products, the Rane CP 52, CP 64 and DA 26.

The MA 3 uses a conventional linear power supply with toroidal transformer. This configuration minimizes the emissions associated with switching supplies and noisier transformer designs. The power supply features *independent secondary supplies for each channel*, minimizing load regulation interaction and crosstalk.

Thermal management is accomplished with a sealed heat-tunnel design incorporating *low velocity* forced air and large aperture openings. This design minimizes the noise usually associated with forced air cooling and *eliminates the need for an air filter*. Forced air cooling allows the amplifier to operate reliably in harsh environments and *avoid the buildup of heat in unventilated racks associated with passive convection cooling*.

Features

- 3 Independent Amplifiers
- 60W per Channel Continuous Average Power into 4Ω, 20-20k Hz
- 40W per Channel Continuous Average Power into 8Ω, 20-20k Hz
- Load Sensitive Dynamic Limiters
- Load Sensitive Headroom Meters
- SPiKe® Protection Circuitry
- High Capacity Linear Power Supply
- Sealed Heat-Tunnel Forced Air Cooling
- Input Level Controls (on rear panel)
- 80 Hz High Pass Filter Selection
- Euroblock Connectors
- UL / cUL / CE Certified

The combination of a solid, conservative power supply and forced-air cooling allows the MA 3 to *simultaneously* deliver 40 watts of *continuous* average power into 8Ω and 60 watts into 4Ω.

SPiKe® *dynamic* protection circuitry completely safeguards each channel against over-voltage, under-voltage, overloads, transients from inductive loads, thermal runaway and *instantaneous* temperature peaks. Biasing is not allowed to occur when an under-voltage condition exists, reducing turn on and turn off transients.

Fast-response limiters allow the MA 3 to tolerate up to 20 dB of overdrive into 8 and 4Ω loads while holding THD below 1%. This means no loss of speech intelligibility or harsh clipping. This feature greatly *increases the dynamic range* of the system without external limiters.

Peak-responding, load-adaptive meters accurately indicate the remaining headroom. The meters are helpful in setting system levels and indicating signal compression.

Balanced inputs with Euroblock connectors are provided. Euroblock output connectors accept up to 12 gauge wire. Rear panel Level controls allow amplifier sensitivity adjustment. Internally selectable 80 Hz highpass filters offer protection against over excursion of small bookshelf speakers and saturation of distribution transformers at low frequencies.

*SPiKe is a registered trademark of National Semiconductor Corporation.

Features and Specifications

Parameter	Specification	Limit	Units	Conditions/Comments
Input:	Euroblock Connector			
Impedance	20k	min.	Ω	Each leg
Maximum Input Level	+20	min.	dBu	
Sensitivity	Off to 0		dBu	Input required for full power; 8Ω
CMR	40	min.	dB	20 Hz to 20 kHz
Highpass Filter	80 Hz (switchable)	±2.5%	Hz	2nd-order butterworth
Amplifier: Gain	27	±0.5	dB	1 kHz
Power Output	40/60	min.	watts	8/4 Ω cont. avg. power, all channels driven
Frequency Response	20 - 20k		Hz	+0, -5 dB
S/N	90	min.	dBr	re: 40W, 8Ω, A-weighted
Crosstalk	-60	max.	dB	1 kHz, 4Ω, all channels driven
THD+N	0.05%	typ.		1 kHz, 40 W, 8Ω, 80 kHz BW
	0.1%	typ.		1 kHz, 60 W, 4Ω, 80 kHz BW
	0.2%	typ.		20 Hz-20 kHz, 35W, 8Ω, 80 kHz BW
Slew Rate	10	min.	V/μs	
Damping Factor	80	min.		8Ω, 1 kHz
On/Off Transient Muting	Active			Drop out 85 VAC (120 VAC unit)
Fan Cooling	Active Constant-Current			Sealed tunnel
Tunnel Power Dissipation	120W; 410 Btu/hr			60W / channel; 4Ω load; all channels driven
SOA	SPiKe*			Safe Operating Area
Limiters: Attack Time	10	typ.	ms	10 dB step
Decay Time	3000	typ.	ms	10 dB step
Threshold	0.1% THD+N	typ.		@1 kHz
Action	1% THD+N	max.		15 dB overdrive (max. level) @ 1 kHz
Meters: Attack Time	20	typ.	ms	10 dB step
Decay Time	500	typ.	ms	10 dB step
Indicators	0, 3, 6, 12	+0, -2	dB	20log (Vmax/Vout) or 10log (Pmax/Pout)
Power Supply: Type	Linear; Toroidal Transformer			Independent secondaries for each channel
.....Input	100 to 240 VAC	±10%	VAC	C14 inlet uses C13 cord
.....Consumption	33.6W; 115 Btu/hr			No load (idle)
.....Total Load & Unit	360W; 1200 Btu/hr			60 W/channel; 4Ω load; all channels driven
Agency Listing:				UL60065+amd1, 7th ed. CAN/CSA-C22.2 No. 60065 UL File E193164
.....120 VAC model	UL, cUL (Canada)			
.....230 VAC model				
.....CE-Safety	LV Directive 2006/95/EC			IEC 60065:2001+A1, 7th ed.
.....CE-EMC	EMC Directive 89/336/EEC			EN 55103-1, -2
Unit: Construction	All Steel			
.....Size	3.5"H x 19"W x 9"D (2U)			(8.9 cm x 48.3 cm x 22.9 cm)
.....Weight	26 lb			(11.8 kg)
Shipping: Size	4.25" x 20.3" x 13.75"			(11 cm x 52 cm x 35 cm)
.....Weight	30 lb			(13.6 kg)

Note: 0 dBu = 0.775 Vrms. *SPiKe is an acronym for Self Peak Instantaneous temperature (Ke) protection circuitry.

Block Diagram

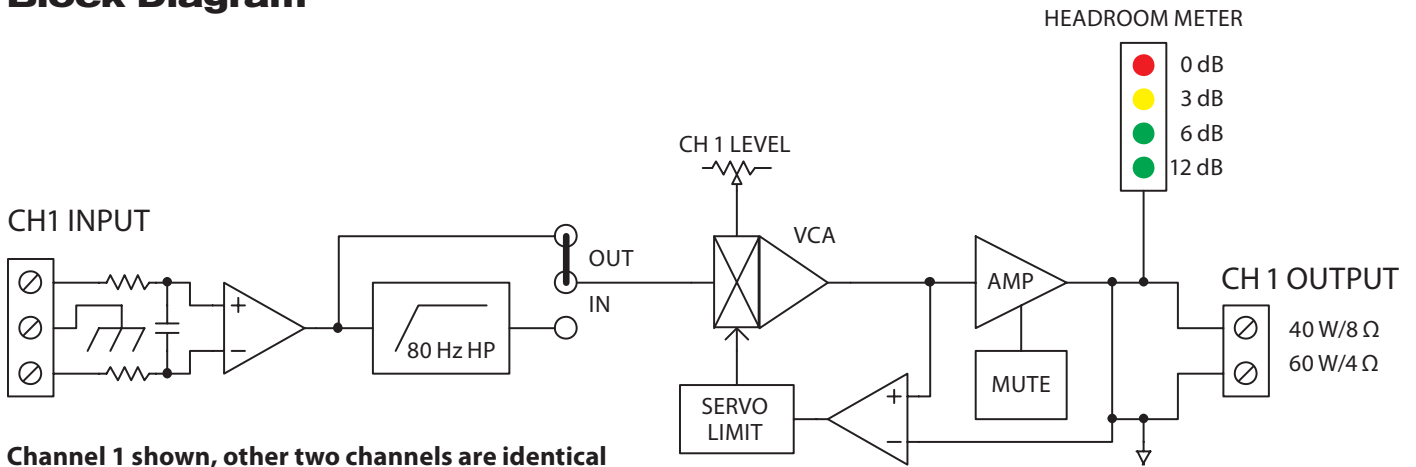

Channel 1 shown, other two channels are identical

Features

Built to be driven hard

The MA 3 Amplifier drives all three channels at the continuous average rated power, indefinitely. It is specifically designed to operate in demanding commercial applications. Very *low emissions* allow the Amplifier to operate in close proximity to signal processing equipment without causing excessive interference. The CP 52, CP 64 and DA 26 may all operate next to the MA 3 in a rack. The high efficiency “heat tunnel” design allows the Amplifier to process severely compressed signals reliably even when installed in a rack with elevated ambient temperatures. Forced air cooling keeps heat away from other equipment.

You won't hear other Zones

The MA 3 is designed to deliver foreground music, background music and paging signals to three different Zones without annoying crosstalk. A quiet office, for example, with a paging signal only, will not hear foreground music playing in the lounge. The high capacity linear power supply incorporates three independent secondary supplies with independent bridge rectifiers and filters. The result is exceptionally good crosstalk figures even with multiple channels driving full power into 4Ω loads.

No bad “spikes”

The MA 3 is designed to operate without interruption of signal with as little as 85 VAC available (120 VAC unit). Even if the Amplifier is operating at full power, the signal will not breakup as the AC line voltage drops to 85 VAC. If the AC line drops lower than 85 VAC the signal mutes without “spikes.” Once AC power is restored, the signal restarts quickly without “spikes” or signal breakup.

The good “SPiKe”

The power Amplifiers in the MA 3 are protected with National Semiconductors’ proprietary SPiKe* protection circuitry. SPiKe protection offers a level of protection not available in conventional amplifiers. It has the ability to instantaneously monitor the

temperature of the power device die, yielding a level of reliability not achievable with discrete designs.

It's OK to light the 0 dB Headroom indicator a lot

The high performance Limiter used in the MA 3 means all the available power can be delivered to the load and not simply held in reserve to avoid overload. There is no need to buy up to *four times* the required power just to prevent occasional system overload. The MA 3 can compress a signal with 9 dB of dynamic *power* range down to a signal with 3 dB of dynamic *power* without loss of speech intelligibility or excessive distortion.

With typical amplifiers, when 40 watts is needed to achieve a required average SPL of 80 dB, the contractor must buy an amplifier rated at no less than 160 watts just to maintain 6 dB of headroom. The figure below illustrates the performance of the MA 3 Limiter.

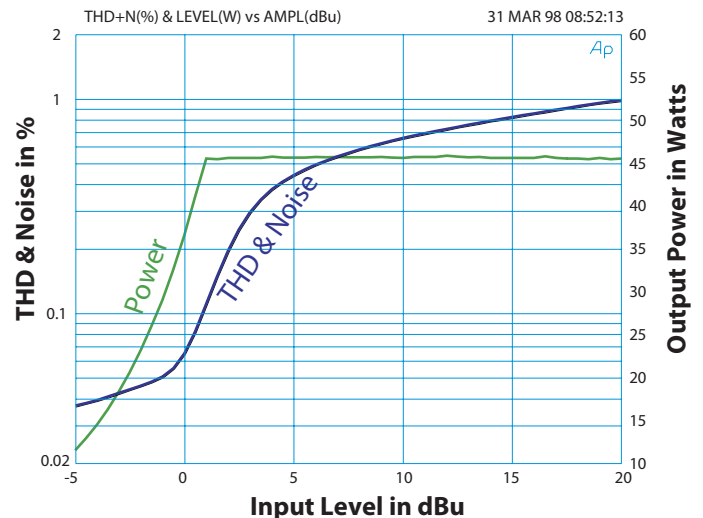

*Spike is a registered trademark of National Semiconductor Corporation. SPiKe is an acronym for **S**elf **P**eak **I**ntermediate (**Ke**) protection circuitry.

Rear Panel

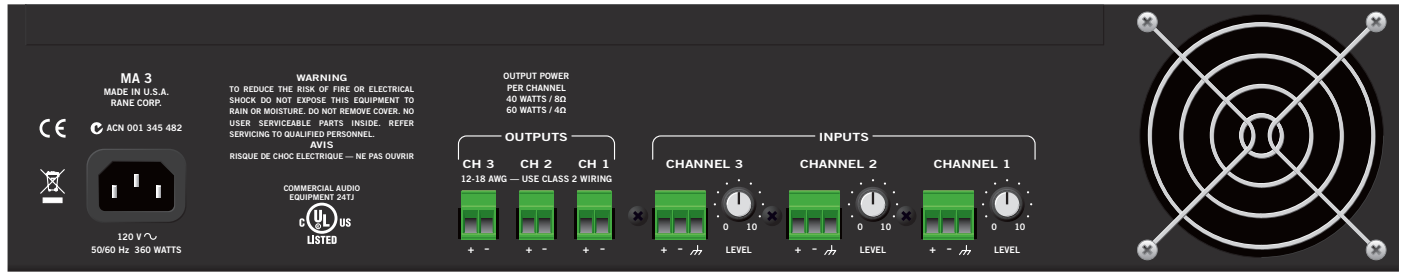

MT 6 Transformer Panel

Constant-voltage transformers may be purchased individually, and up to six may be mounted in any combination on the back of a 2U high MT 6 rack panel:

- TF 407 is a 40W, 70.7V Distribution Transformer
- TF 410 is a 40W, 100V Distribution Transformer

Both transformers rated at 40 watts, 50 Hz to 15k Hz ±1 dB, with 0.5 dB insertion loss. Each transformer comes with crimp-on tabs, wire nuts, and mounting screws.

For applications, see the RaneNote “Constant-Voltage Audio Distribution Systems: 25, 70.7 & 100 Volts.”



MT 6 front panel

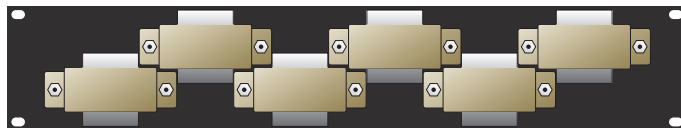

MT 6 rear panel with six transformers installed.

Architectural Specifications

The MA 3 shall be a three channel amplifier. It shall deliver 40 watts continuous average power into 8 ohms and 60 watts continuous average power into 4 ohms. The amplifier shall have balanced inputs with Euroblock connectors and Euroblock output connectors capable of accepting 12 gauge wire. Input level controls shall allow adjustment of input sensitivity. An internal means of selecting 80 Hz highpass 2nd-order butterworth filters shall be provided. Load sensitive limiter circuits shall expand the dynamic range of the amplifiers and prevent clipping and the associated loss of speech intelligibility.

The power supply shall use a conventional linear supply with means of operating from 120 VAC 50/60 Hz or 230 VAC 50 Hz. An IEC connector with integral fuse and IEC cord shall be utilized. A front panel mounted power switch shall be provided with a “power-on” indicator.

Thermal management shall employ forced air cooling, allowing the amplifiers to operate reliable in unventilated racks at elevated ambient temperatures. The design shall incorporate a sealed heat tunnel with large aperture openings and low velocity air flow to minimize noise and eliminate the need for air filtering and the associated maintenance.

The design shall provide protection against overvoltage, undervoltage, overloads, transients from inductive loads, thermal runaway and *instantaneous* temperature peaks. Load sensitive headroom meters shall provide indication of 0, 3, 6 and 12 dB of remaining headroom.

The main chassis shall be constructed of 12 gauge, cold-rolled steel capable of reliably supporting rack mount applications. The unit shall be UL listed and cUL certified.

The unit shall be a Rane Corporation model MA 3.