

QUICK START

If you don't get any further, at least read this section to get the best gain structure out of the MLM 103.

INPUTS 1 through **6** may be microphone or line level. The choice between the two is made by setting the Input's **LINE** push-button on the rear panel.

Push the **PHANTOM POWER** button (when needed) for each pair of Inputs.

Using a screwdriver, adjust the **TRIM** for each Input so that the front panel **OL** LED illuminates only occasionally during extreme peaks. The three-band Equalizer settings will influence this, so keep an eye on the **OL** when making EQ adjustments. Now adjust the **LEVEL** for each Input.

Assign each Input to the desired Output by pushing any combination of the **A**, **B**, or **AUX** **ASSIGN** buttons.

INPUTS 7/8 and **9/10** are stereo line level Inputs.

Assign each stereo input to the desired output as follows:

When the **ASSIGN** button is engaged and the **MONO** button is *not* engaged, **INPUT 7** (or **9**) is routed to the **A** Output, while **INPUT 8** (or **10**) is routed to the **B** Output.

When the both the **ASSIGN** and **MONO** buttons are engaged, both Inputs of **7/8** (or **9/10**) will route to both the **A** and **B** Output.

The **AUX** **ASSIGN** button is always a mono mix of the stereo channel.

FRONT PANEL DESCRIPTION

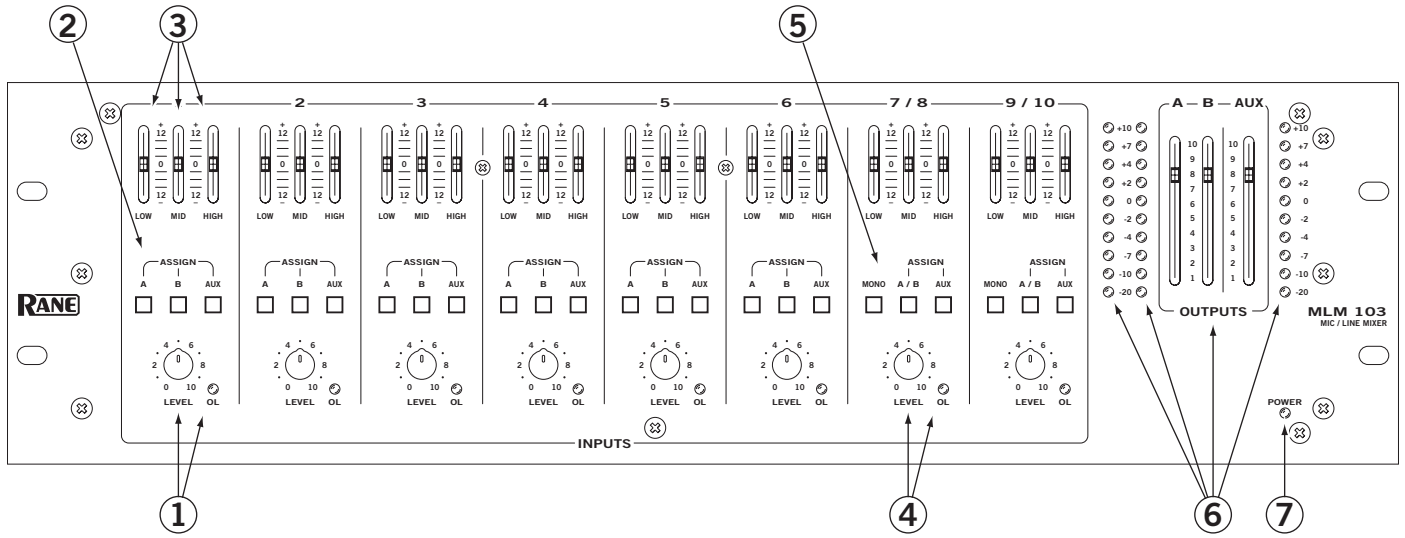

- ① **Mic/Line Input LEVEL controls 1-6** determine the amount of signal to be delivered to the assigned Outputs. The Overload light monitors the signal level before and after the Equalizer. If this illuminates steadily, turn down the LEVEL or EQ controls to prevent distortion.
- ② **Mic/Line Output ASSIGN buttons.** When the A button is engaged, the Mic/Line Input's audio is routed to Output A. When the B button is engaged, the Input's audio is routed to Output B. When the AUX button is engaged, the Input's audio is routed to the Aux Output. Any (or all) of the ASSIGN buttons can be engaged simultaneously.
- ③ **Equalizer controls** are used to contour the frequency response of the desired Input. LOW affects frequencies below 300 Hz, MID affects 300 Hz to 3.3 kHz, and HIGH affects frequencies above 3.3 kHz. The Equalizer sounds best and potential overload is avoided when at least one of the three bands is set to cut (below 0).
- ④ **Stereo Line INPUT LEVEL controls 7/8 and 9/10** determine the amount of stereo or mono line signal to be delivered to the assigned Outputs. The Stereo Line Overload light monitors the signal levels after the Equalizer and after the line gain stage. If this illuminates steadily, turn down the LEVEL or EQ controls to prevent distortion.
- ⑤ **Stereo Line Output ASSIGN buttons.** When the A/B assign button is engaged and the MONO button is not engaged, Input 7 (or 9) is routed to the A Output, while Input 8 (or 10) is routed to the B Output. When both the A/B ASSIGN and MONO buttons are engaged, both Inputs of 7 and 8 (or 9 and 10) will be routed to both the A and B Output. The AUX ASSIGN button is a mono mix of the stereo Inputs.
- ⑥ **A, B and AUX OUTPUT LEVEL controls** set the Output Level for A, B and AUX Outputs. The Output Meters indicate the overall levels of Output A, Output B and the AUX Output. The Meters are "peak hold".
- ⑦ **POWER indicator** lights whenever adequate power is applied to the unit.

REAR PANEL DESCRIPTION

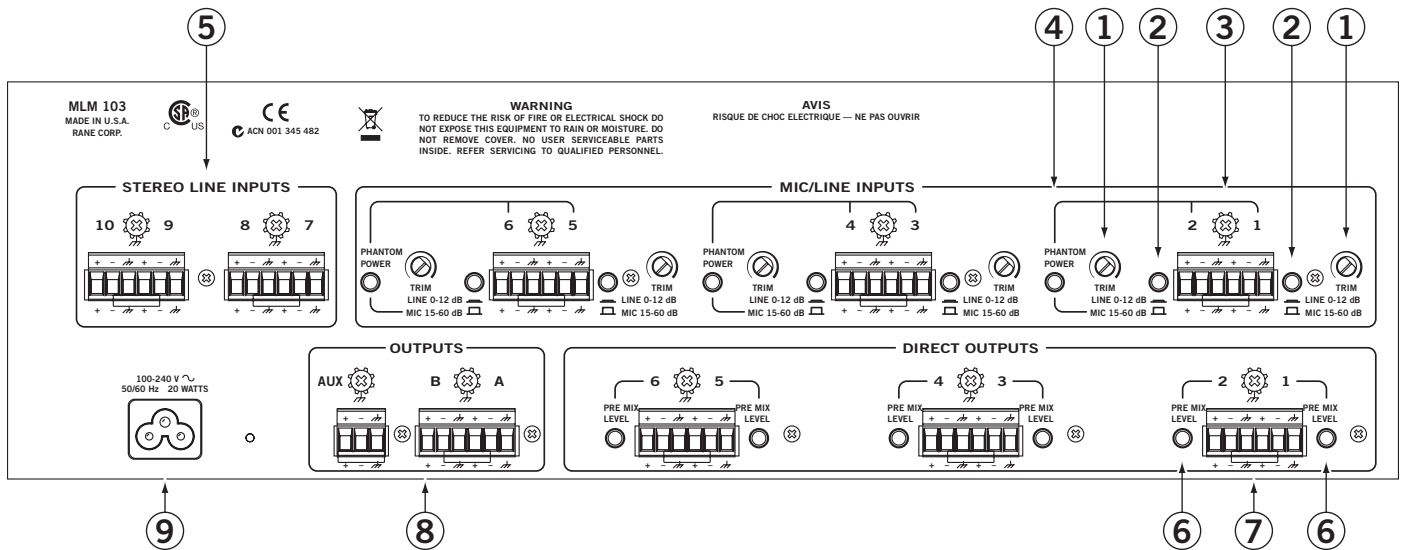

- ① **MIC/LINE INPUT TRIM controls 1-6** adjust the input gain of the Mic/Line Inputs. The gain range for Mic level is 12 to 60 dB. The gain range for Line level is -4 to 12 dB.
- ② **LINE/MIC INPUT buttons 1-6** switch the sensitivity and input impedance for either a microphone or line input. Mic level is selected when the button is in the “out” position. Line level is selected when the button is in the “in” position.
- ③ **MIC/LINE INPUT connectors 1-6** are balanced Euroblocks that connect either microphone or line signals.
- ④ **PHANTOM POWER button** applies 12 volt phantom power to each pair of Mic/Line Inputs, only when the LINE/MIC INPUT button (②) is set to the MIC “out” position.
- ⑤ **STEREO LINE INPUTS 7/8 and 9/10** are pairs of balanced Euroblock connectors, accommodating stereo or mono line level signals.
- ⑥ **PRE/post MIX LEVEL DIRECT OUTPUT buttons.** When this switch is in the “in” position, the Direct Output signal is *not* affected by the Input’s Level control. When this switch is in the “out” position, the Direct Output signal *is* affected by the Input’s Level control.
- ⑦ **DIRECT OUTPUTS** are balanced Euroblocks that directly connect each Mic/Line Input signal to other audio devices as needed. These Direct Outputs are post-Equalizer.
- ⑧ **A, B and AUX OUTPUT connectors.** One 6-post balanced Euroblock connects the A mix and the B mix to other audio devices as needed. The other 3-post balanced Euroblock connects the AUX mix to other audio devices as needed.
- ⑨ The IEC appliance input jack uses a C5 cord, connected to AC mains using a line cord appropriate for your area. The high efficiency switching power supply used in the MLM 103 operates at voltages from 100 VAC to 240 VAC, 50 or 60 Hz. To prevent accidental shutoff during the president’s speech, there is no front panel power switch. When applying power to the system, remember to turn power amplifiers on *last*.

CONNECTION

INPUTS

The MLM 103 has ten balanced Euroblock Inputs. Use only shielded cable, #12 to #24 AWG. For best noise rejection use two-conductor-plus-shielded wire, even for unbalanced operation. Connect the non-inverting (positive) audio lines to the “+” terminals, and the inverting (negative) lines to the “-” terminals. Connect the shields to the “ground” terminals.

For those installations where the MLM 103’s internal shield-to-chassis connection causes interference, connect the shields directly to chassis PEM nuts directly above each pair of Euroblock connectors. Be sure to bite through the paint with the star washer and keep the shields wrapped around the audio conductors as much as possible. For the “theoretical” best ElectroMagnetic Interference (EMI) immunity, connect the shields at both ends of the cables. (For more information on connections, see the RaneNote, “Sound System Interconnection” later in this manual or on Rane’s website.)

MONO INPUTS 1-6 can accept either mic or line level sources. When connecting line level signals, push the rear panel button *in* for LINE. For mic signals, be sure the button is in the MIC (*out*) position.

STEREO INPUTS 7/8 and 9/10 accept line level stereo and mono sources.

OUTPUTS

The MLM 103’s OUTPUTS (and DIRECT OUTPUTS) are balanced. The same wiring conventions as the Euroblock Inputs apply.

OPERATION

MONO MICROPHONE/LINE LEVEL INPUTS 1-6

The rear-panel MIC/LINE INPUT TRIM adjusts the input gain before the front panel LEVEL controls. When an Input’s LINE/MIC button is in the “out” position (Mic Level), the gain range is 12 to 60 dB. When an Input’s LINE/MIC button is in the “in” position (Line Level), the gain range is -4 to 12 dB.

First, input some “loud” source material (like a pop metal or disco CD, give a kid a mic, etc). Then, using a screwdriver, adjust the TRIM for each Input so that the front panel OL LED illuminates only occasionally during extreme peaks. The 3-band Equalizer settings will influence this, so keep on eye on the OL when making EQ adjustments.

Push the PHANTOM POWER button (when needed) for each pair of Inputs. If the LINE/MIC button is engaged (Line Level), Phantom Power is automatically defeated for that Input. The PHANTOM POWER button activates 12 volts which is sufficient power for all but the most esoteric condenser mics. If in doubt, check the manufacturer’s microphone specs.

Assign each Input to the desired Output by pushing any combination of the A, B or AUX ASSIGN buttons.

The LEVEL of each Input can now be adjusted as needed without danger of blowing your speakers, or scaring the neighbors, whichever you deem worse.

STEREO LINE LEVEL INPUTS 7/8 and 9/10

When a stereo source (CD, DVD, Satellite radio, etc.) is connected to Inputs 7/8 (or 9/10), the routing is as follows:

When the ASSIGN button is engaged and the MONO button is *not* engaged, INPUT 7 (or 9) is routed to the A Output, while INPUT 8 (or 10) is routed to the B Output.

When both the ASSIGN and MONO buttons are engaged, a mono mix of INPUTs 7/8 (or 9/10) will be routed to both the A and B Outputs.

The AUX ASSIGN button is always a mono mix of the stereo channel.

OUTPUT LEVELS

After all of the Mic/Line and Stereo Input Levels have been adjusted and routed, adjust the OUTPUT faders so the Meters peak average around 0 to +2.

SECURITY COVER

The MLM 103 comes with an installed security cover for the EQ and ASSIGN switches only, leaving the LEVEL controls and metering exposed for regular operation. This feature is valuable when you want to protect those painstaking settings from casual operators.

The cover is removed and replaced by two screws. If the security cover will not be used, remove the chrome standoffs from the front panel and replace with the black screws in these same locations.