

QUICK START

Sure this seems like a simple enough box. 4 Inputs, 2 Outputs and an Effects Loop. Fine. But at least read this section to get the best signal out of your unit and avoid potential problems. We'll be quick, promise!

Each Input section features microphone-level **XLR** and line-level $\frac{1}{4}$ " **TRS** Inputs. *Use only one Input for each channel.* Both Inputs are balanced.

If you are using condenser mics, flip the **PHANTOM POWER** switches to the **ON** position. For dynamic mics and line-level devices, leave these switches **OFF**. Phantom Power only affects the XLR Inputs, not the $\frac{1}{4}$ " TRS Inputs.

If an **Input Overload** indicator lights, this is your clue to turn down its **GAIN** trim on the rear of the unit.

The **Output Overload** indicator shows the sum of the 4 Input channels, but is located before the **OUTPUT LEVEL** control. Therefore, the **OUTPUT LEVEL** control *cannot* correct an **Output Overload** condition. Instead, turn down the **LEVEL** of one or more of the Input channels. The **Output Overload** indicator should remain off.

The **OUTPUT MIC/LINE switch** changes the balanced XLR and TRS Outputs to either **LINE**-level or **MIC**-level. Be aware of what sort of signal your mixer or amplifier wants to see before you scare yourself.

FRONT PANEL DESCRIPTION

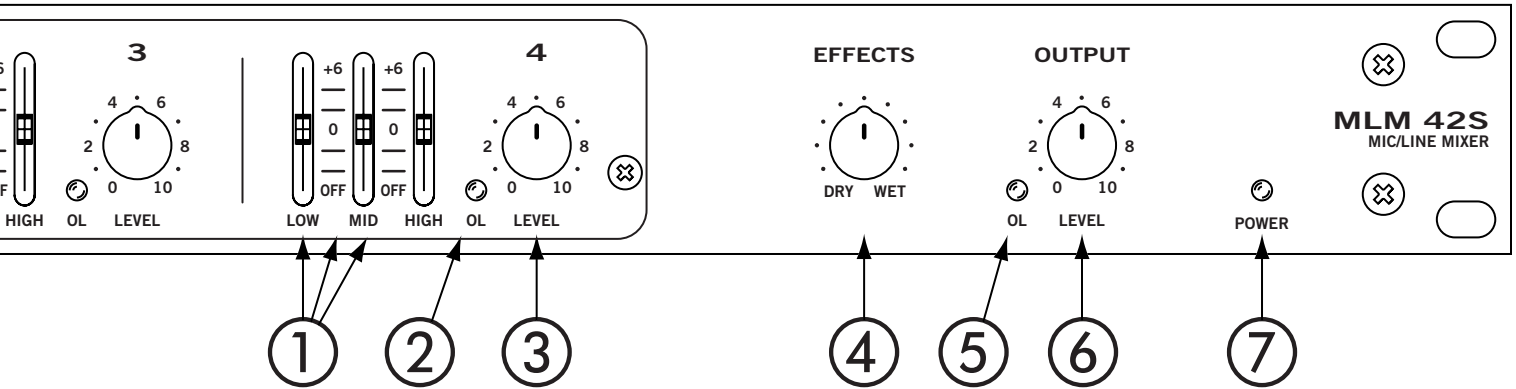

- ① **LOW / MID / HIGH tone controls** on each input channel are *Accelerated-Slope™*, delivering more control, constant phase response, and less interaction between bands than normal tone controls. The LOW/MID corner frequency is 300 Hz. The MID/HIGH corner frequency is 4 kHz. Each band allows 6 dB of boost and *full cut*.
- ② **Input Overload indicators** should remain off during the loudest expected program material. If you see one light up, turn down the rear panel Input GAIN.
- ③ **Input LEVEL controls** set the volume for each channel. These work along with the rear panel GAIN controls for maximum signal. To achieve the smoothest mix possible, set the GAIN control on the rear panel to allow near full range operation of the mix Level control without lighting up the Input Overload indicator.
- ④ **EFFECTS DRY / WET control** adjusts the mix between the sum of the four Inputs (DRY) and the Effects Return jack (WET). When used with an external effects processor, the DRY/WET pan control adjusts how much processed, versus unprocessed, signal appears in the final output mix. See the EFFECTS LOOP section on page Manual-4 for more uses.
- ⑤ **Output Overload indicator** is located before the Output Level control. Therefore, the Output Level control *cannot* be used to correct an Output Overload condition. An Output Overload condition is corrected by turning down one or more of the Input LEVELs. Your goal is to keep this indicator *off*.
- ⑥ **OUTPUT LEVEL control** determines the level going to all Outputs.
- ⑦ **POWER indicator.** When the yellow LED is lit, the MLM 42S is ready to go.

REAR PANEL DESCRIPTION

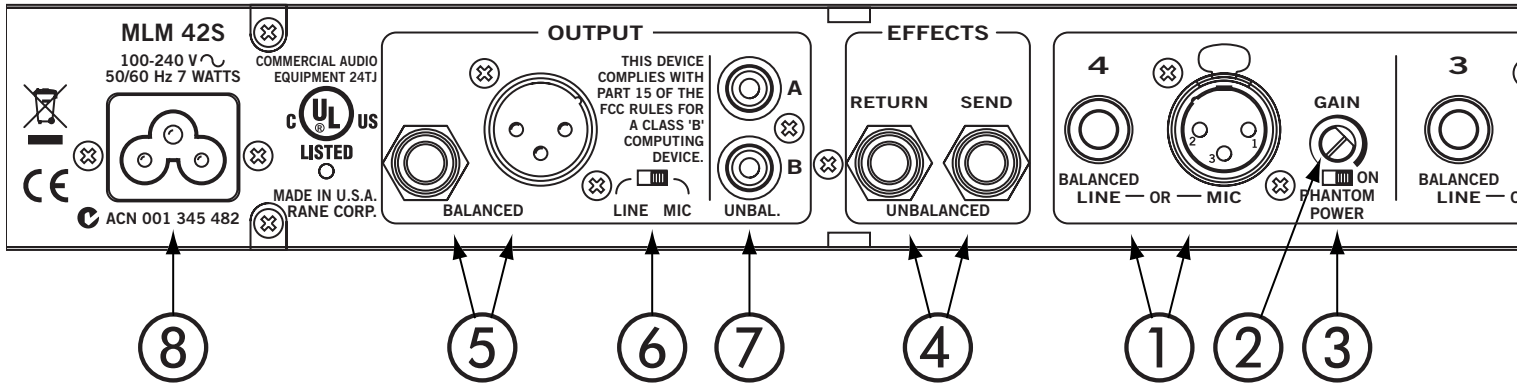

- ① **INPUTS 1 through 4** feature MIC-level XLR and LINE-level ¼" TRS connectors. *Use only one of these Inputs for each channel.* Both Inputs are balanced. A mono ¼" TS plug may be inserted into the LINE input if necessary, but better results come from a balanced TRS plug. See the RaneNote, "Sound System Interconnection" included with this manual.
- ② **PHANTOM POWER switch** provides 15 volts to condenser microphones plugged in the MIC Input.
- ③ **GAIN trim control** sets the initial gain of the Input so the front panel LEVEL control has the most latitude without distortion. When the XLR MIC Input is used, the range of the GAIN is 12 to 50 dB and Phantom Power may be selected. When the TRS LINE Input is used, the range of the GAIN is 0 to 12 dB and Phantom Power is disabled.
- ④ **EFFECTS SEND & RETURN** loop connects external effects processors or expands to other mixers. See page Manual-4.
- ⑤ **¼" TRS and XLR Balanced OUTPUT** jacks are provided for convenience. Both connectors may be used simultaneously.
- ⑥ **OUTPUT LINE / MIC switch** changes both balanced XLR and ¼" TRS Outputs to either LINE-level or MIC-level. Many DJ mixers have microphone engage and talk-over functions associated with the microphone inputs. By connecting the MLM 42S directly to one of these microphone inputs, you are able to take advantage of these features.
- ⑦ **A & B Unbalanced RCA Outputs** provide connection to line-level inputs. The Outputs of A and B are identical.
- ⑧ **Universal Voltage Input:** via a miniature IEC 60320 C6 appliance inlet. This mates with an IEC 60320 C5 line cord (USA domestic). Do **not** lift the ground connection!

EFFECTS LOOP

The Effects loop provides a means of processing the mix of the four Inputs. Send and Return are unbalanced 1/4" TS (tip/sleeve), so keep cable runs to these jacks as short as possible to avoid hum and noise (under 10 feet [3 meters]). Typical effects processors include reverb, gate, compressor, limiter, EQ, etc.

The mix of the four Inputs appears on the EFFECTS SEND Output. This Output provides the input to the external processor.

The EFFECTS RETURN Input receives the output from the effects processor. To prevent loss of signal when a plug is not installed in the RETURN jack, this jack is a switching type. The SEND is internally connected to the RETURN when a plug is not inserted. The DRY/WET pan control allows the user to control how much processed versus unprocessed signal appears in the final output mix.

An alternative use for the EFFECTS loop is for Expand Output and Expand Input. For example, if you wish to use two mixers, the SEND Output of the first mixer can drive the RETURN Input of the second mixer. The relative mix level of mixer one versus mixer two is determined by the DRY/WET pan control of the second mixer.

Other applications for the EFFECTS loop may use only the SEND Output or only the RETURN Input. For example, a drum machine, keyboard or other mono source may be connected to the RETURN Input. The relative mix of the 4 Inputs versus the source present at the RETURN Input is determined by the DRY/WET pan control. The SEND may be used as a direct Output for recording.

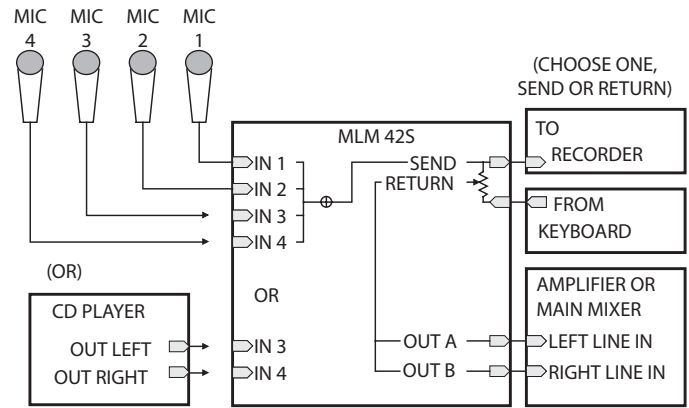

4 Mic Mixer, or 2 Mics and a CD Player;

Send to a Recorder, or Return a 5th Input from another mono source.

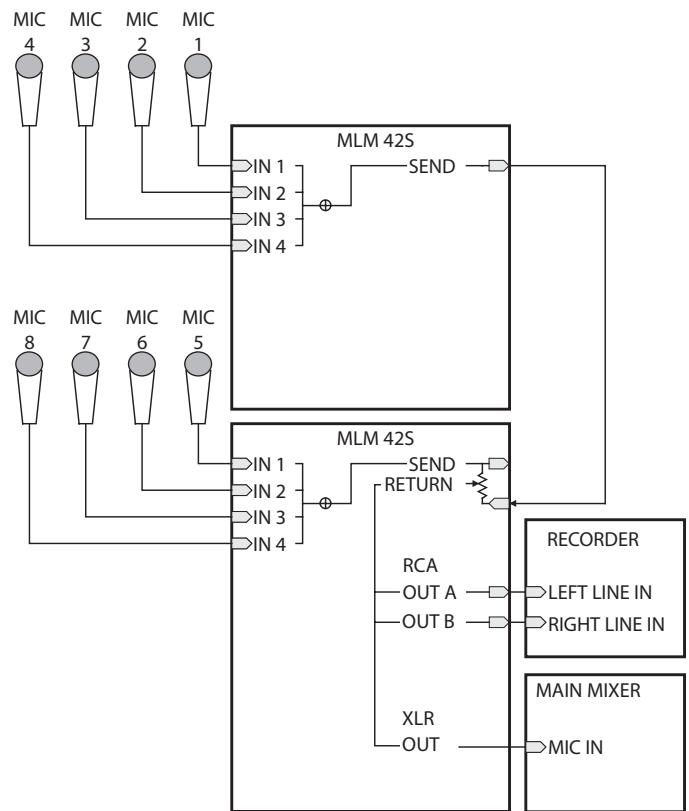

Connecting two MLM 42S's for 8 Mic Inputs