



General Description

The PE 17 Parametric Equalizer/Notch Filter advances the features and performance of the popular Rane PE 15 Parametric Equalizer design. The PE 17 adds separate In and Out Gain controls, sweepable Low and High Cut Filters, 100% overlapping bands, and improved dynamic range and noise performance. Aimed at all critical applications, including digital audio recording studios, the PE 17 stands alone as the parametric of choice for sound professionals. Special design techniques and components used in the design of the PE 17 guarantee residual noise levels below digital recording equipment. This makes the PE 17 ideally suited for all critical digital audio studio, sound reinforcement and broadcast applications.

The adjustable band limiting Filters offer great appeal in tailoring each sound systems overall frequency response exactly to its application. The range of the Low Cut is 10 Hz to 250 Hz, while the High Cut is 3 kHz to 40 kHz. Both have maximally flat 12 dB/octave Butterworth responses.

All five parametric bands are identical and offer 100% overlap. This allows the PE 17 to be configured one time as a 5-band subwoofer parametric equalizer, with all bands covering the range of 10 Hz to 200 Hz, and another time as a high frequency unit, with five bands covering the range from 1 kHz to 20 kHz, or yet another time, with each band covering five separate parts of the audio spectrum — anyway you want it. Additionally, you may vary each filter's bandwidth from as narrow as *1/30 of an octave* to as wide as 2 octaves, and adjust the Level over a boost/cut

range of +12 dB to -15 dB. The extra-deep cut range, when used with a narrow Bandwidth setting, is effective against troublesome feedback frequencies. Specially designed circuits make all these adjustments completely independent. To you, this means the ability to change all controls in any order without affecting the others. This flexibility makes the PE 17 ideal for all audio contouring applications. Anything from the sharpest notch to widest contouring.

Individual Bypass switches and LED indicators allow separate auditioning of each band. An overall Bypass relay provides for “hard-wiring” the Input connectors to the Output connectors anytime the Bypass switch is activated or upon power failure, thereby ensuring a fail-safe condition. Other front panel features include a system Overload light that continuously monitors five critical internal nodes, a Power indicator, and separate ± 12 dB Input and Output Gain controls.

The PE 17 rear panel provides XLR and $\frac{1}{4}$ " TRS connectors. The balanced Input stage design uses a precise instrumentation amplifier to provide superior common-mode rejection of unwanted signals. The balanced Output stage uses a member from the “cross-coupled” family of high current line drivers. With this design extremely long lines may be driven with impunity.

A single $\frac{1}{4}$ " Patch I/O jack, wired in the conventional tip=in/ring=out manner provides a convenient method to patch the PE 17 into console insert points (wired: tip=send/ring=return) using only a single stereo (TRS) cable.

Features

- 120 dB (20-Bit Equivalent) Dynamic Range
- Separate ± 12 dB Input/Output Gain Controls
- Separate Sweepable Low & High Cut Filters
- Five Fully Parametric Bands with 100% Overlap
- 10 Hz-20 kHz Filter Frequency Sweep
- .03 TO 2.0 Octave Variable Bandwidth
- +12 dB/-15 dB Boost/Cut Range
- Overall and Individual Band Bypass Switches & Indicators
- Multipoint Overload Monitoring Indicator
- Automatic Fail-Safe Bypass Relay
- Balanced XLR & $\frac{1}{4}$ " TRS Connectors
- Handy Patch I/O Jack for Insert Point Use
- UL/CSA Remote Power Supply (120V)
- CE (Low Voltage & EMC) Remote Power Supply (230V)



Features and Specifications

Parameter	Specification	Limit	Units	Conditions/Comments
Equalizer: Bands	5			
.....Type	Full Parametric			
.....Range	Boost: +12; Cut: -15	1	dB	Minimum phase design
.....Bandwidth	.03 to 2.0 octaves	5	%	Continuous sweep
.....Sweep	20:1	5	%	
	10 Hz to 200 Hz			Freq Switch: x.1
	100 Hz to 2 kHz			Freq Switch: x1
	1 kHz to 20 kHz			Freq Switch: x10
Inputs: Type	Active Balanced			True instrumentation amplifier
.....Connectors	XLR & ¼" TRS			
.....Balanced Impedance	10.09k	0.1%	Ω	Each leg to ground
.....Maximum Level	+23	1	dBu	
.....Common Mode Rejection	65	1	dB	20-1 kHz, rising to 50 dB @ 20 kHz
Outputs: Type	Active Balanced			Servo cross-coupled design
.....Connectors	XLR & ¼" TRS			
.....Balanced Impedance	50	10%	Ω	
.....Maximum Level	+22 ≥600 Ω	1	dBu	
In & Out Gain Range	±12	±2	dB	
RFI Filters	Yes			
On/Off Transient Muting	Yes			
Fail-safe Bypass Relay	Yes			Auto-bypass with power loss
Overload LED Threshold	+20	1	dBu	Output or any internal level
Variable Low-Cut Filter	10 Hz-250 Hz, 12 dB per octave	3%	Hz	Butterworth
Variable High-Cut Filter	3 kHz-40 kHz, 12 dB per octave	3%	Hz	Butterworth
Frequency Response	20 Hz-20 kHz	±0.5	dB	
THD+Noise	0.005	.001	%	+4 dBu, 20-20 kHz, 80 kHz BW
Dynamic Range	120	2	dB	Noise floor-to-clipping into ≥2 kΩ
Signal-to-Noise Ratio	re +4 dBu, 20 kHz Noise BW	98	2	dB
				Boost/Cuts centered, unity gain
Unit: Agency Listing				
.....120 VAC model	Class 2 Equipment UL & CSA			National Electrical Code Exempt Class 2 Equipment
.....230 VAC model	CE-EMC CE-Safety Exempt			EMC directive 89/336/EEC Article 1 of LV Directive 73/23/EEC
Power Supply: Agency Listing				
.....120 VAC model	UL CSA			Class 2 Equipment File no. E88261 File no. LR58948
.....230 VAC model	CE-EMC CE-Safety			EMC Directive 89/336/EEC LV Directive 73/23/EEC
.....100 VAC model	Built to JIS			Japan only
Power Supply Requirement	18 VAC w/center tap	0.1	Vrms	Rane RS 1
Maximum Current	450		mA	RMS current from remote supply
Unit: Construction	All Steel			
.....Size	1.75"H x 19"W x 5.3"D (1U)			(4.4 cm x 48.3 cm x 13.5 cm)
.....Weight	5 lb			(2.3 kg)
Shipping: Size	4.25" x 20.3" x 13.75"			(18 cm x 56 cm x 33 cm)
.....Weight	9 lb			(4.1kg)
<i>Note: 0 dBu=0.775 Vrms</i>				

Block Diagram

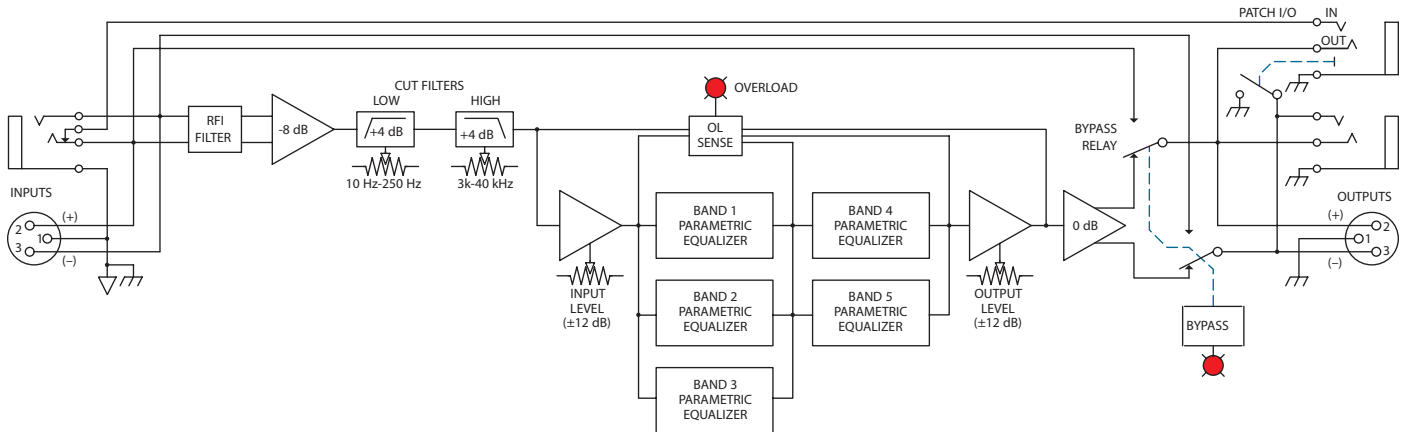

Application Information

If you are familiar with any parametric equalizer, you will find the PE 17 very friendly, and quite easy to operate. Only a few things need discussing.

One of these, is the fact that you can *not* use the Patch I/O jack and the main jacks at the same time. This is an *either/or* situation: *either* use the Patch I/O jack *or* use the main jacks. Similarly, you cannot use *both* of the Input jacks at the same time; they do not sum. Make a choice. Do not use them to mix two signals. It won't work.

The Output jacks, on the other hand, may both be used, if you need them. So. Driving two things is okay; summing two things is not. Enough.

For optimum noise performance, you should take as much gain at the Input as you can, with a corresponding reduction at the Output. This is done by moving both Gain sliders upward. Note that the *In* control is calibrated top-to-bottom +12 dB to -12 dB, while the *Out* control is calibrated just opposite. Thus, by moving both sliders together, you always maintain unity gain through the Equalizer, but you vary how much gain/attenuation occurs at the Input or Output of the unit. Therefore, by operating the unit with both sliders as high as possible, you take a lot of gain up-front, while simultaneously reducing the signal (and noise) at the Output. Use the Overload light as a guide: occasionally lighting is set just right. Continuously lighting is too much gain, while never lighting is too little gain.

The PE 17 is a parallel *and* serial design. Referring to the block diagram above, you can see that Bands 1, 2 and 3 are arranged in a parallel fashion in series with paralleled Bands 4 and 5. This unique topology offers an optimum combination of the minimum phase shift and delay times of parallel designs with the extreme cut or boost settings available from series designs. So keep in mind that for extreme boost/cut settings *use two Bands in series* (e.g., Bands 3 and 4), that way, their dB boost/cut values directly add. For example -15 dB on both results in a total of -30 dB. For parallel bands, their boost/cut dB values do not directly add. We know this could be confusing, but so is the rest of life!

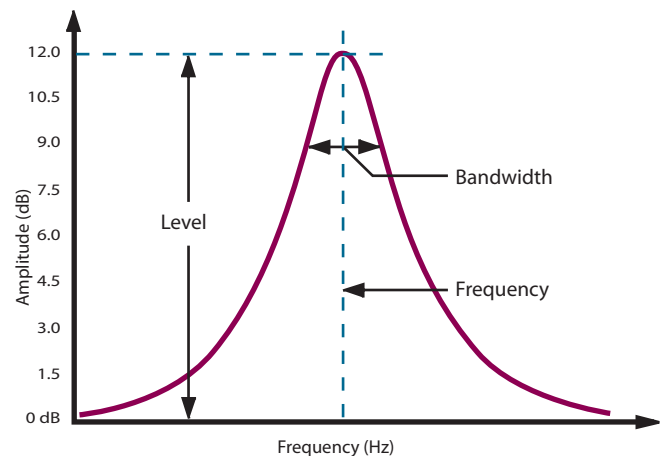

Rear Panel

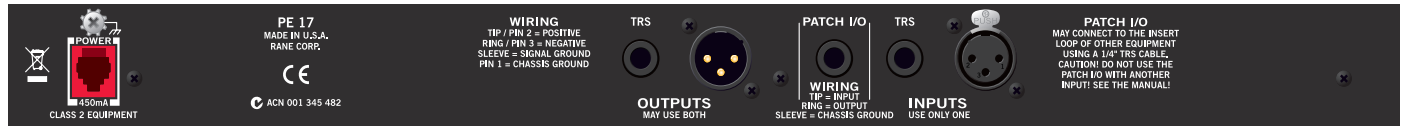

Architectural Specifications

The parametric equalizer/notch filter shall be designed for digital audio recording applications with a minimum dynamic range of 120 dB and a signal-to-noise ratio of at least 98 dB re +4 dBu (20 kHz noise bandwidth).

The parametric equalizer shall be a one (1) channel, five (5) band unit with variable low-cut and high-cut filters, and be designed for rack-mounting requiring only one (1) rack space.

Separate bypass switches with LED indicators shall be provided for each band. Each band shall have separate controls to sweep frequency over a 20:1 range (with a 3-position range switch), adjust bandwidth from .03 to 2.0 octaves and set amplitude control to a maximum of +12 dB boost and -15 dB cut. Overall input and output gain controls shall be included with a range of ±12 dB.

The inputs shall be active balanced/unbalanced designs terminated with XLR and ¼" TRS (tip-ring-sleeve) connectors. The outputs shall be active balanced designs terminated with XLR and ¼" TRS connectors.

RFI filters shall be provided. The unit shall provide a bypass relay feature wired for fail-safe operation upon power failure. An LED shall be provided to indicate overload condition.

The unit shall be powered from a UL listed, CSA and CE certified external AC power supply. This external supply shall be provided with each unit and be available with either a 120 VAC or a 230 VAC primary. The unit shall be entirely constructed from cold-rolled steel.

The unit shall be a Rane Corporation Model PE 17.

Available Accessories

- SC 1.7 Security Cover