

General Description

The Rane RA 30 Realtime Analyzer is a single rack space unit providing 30 bands of realtime frequency/amplitude information in a 5-LED per band format. The RA 30 serves three functions:

- Realtime Analyzer with Pink Noise generator
- SPL Meter
- Stereo VU Meter with Peak Hold

In RTA (Real Time Analyzer) mode, the RA 30 is used to visually judge the character of the Pink Noise signal (or any sound) received by the measurement microphone. A Pink Noise generator is built into the RA 30 with an on/off switch. The operator may now adjust an external 1/3-octave equalizer for optimum response of a sound system based on the readings presented by the LED display.

Broadband signals applied to either the Mic or Line Inputs of the RA 30 are divided into 1/3-octave increments by IEC 61260 Class 2 filters. The outputs of the filters are displayed on the front panel to visually indicate the amplitude of each band, in user-selectable 1, 3 or 6 dB per LED scales. A Normalize button sets the 0 dB reference to the maximum band level.

In SPL (Sound Pressure Level) meter mode, the display is read horizontally and calibrated to a 1 dB resolution. The calibrated mic included with the RA 30 must be used, with the Gain control in the detented ‘CAL’ position. A- or C-weighting filters are user selectable. This mode accurately displays SPL readings from a minimum of 51 dBA to a maximum of 120 dBA. The Cal Mic Input auto ranges for maximized operation.

Stereo VU meter mode is automatically enabled when the Line input source is selected. It has a 1.5 dB resolution, and can

be calibrated to accommodate +4 dBu or -10 dBV signals. Two horizontal rows of yellow LEDs indicate the VU level. The top row corresponds to the Left Input, and the bottom row corresponds to the Right Input. Levels above +3 dB on the VU scale switch to the red LED rows.

The VU meter incorporates an instantaneous Peak Hold function with a 2-second hold time. Peak Hold is enabled or disabled by pressing the NORM button. The peak value is displayed with a single LED for each channel. If the held peak value is greater than +12 dB on the VU scale, the +12 dB LEDs stay illuminated. In this case, the Input gain can be decreased until the peak value is not “stuck” at +12 dB. For a calibrated peak measurement, the input gain can be set to minimum, which sets the 0 dB mark on the VU scale to +16 dBu.

The Rane MIC 2 condenser microphone is a professional quality back-electret condenser microphone with an omnidirectional pickup pattern. This microphone is supplied with each RA 30, and connects to the front panel Mic Input jack *only*. The tapered aluminum mic housing fits most mic stand clips (one is included), and comes complete with a 25 foot (7.6 meter) cable to facilitate distant placement of the mic from the analyzer. These factory tested mics are flat to within 1 dB from 20 Hz to 16 kHz. An Aux Mic Input is provided on the rear panel, facilitating the use of other microphones.

The rear panel of the RA 30 includes a Pink Noise Output jack, Aux Mic Input (XLR), stereo Line Inputs (1/4" balanced, can operate in mono by using the left input only), and a recessed Pink Noise Level adjustment.

Features

- RTA, SPL Meter, and Stereo VU Meter in one rack space
- 30 IEC Class 2 Filter Bands from 25 Hz to 20 kHz
- 5-color LED display per band
- Digital Pink Noise generator
- Flat-response Microphone and clip with 25-foot cable
- ±6 / 3 / 1 dB Selectable RTA Scale with Normalize function
- Aux Microphone Input, Stereo or Mono Line Inputs
- A- & C-weighting switch in SPL mode
- Peak Hold function in stereo VU mode
- Analyzer Sensitivity and Pink Noise Level controls

Rane MIC 2 (included)

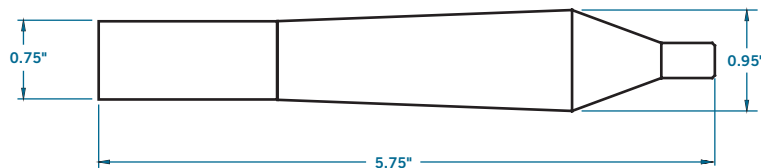



Parameter	Specification	Limit	Units	Conditions/Comments
Cal Mic Input: Type	Active Unbalanced			3-pin XLR-Female type, pin 2(+)
.....Impedance	2k	1%	Ω	1 kHz
.....T Power Voltage	2	5%	VDC	Pin 2 of connector, 1 mA max
.....T Power Source Resist.	2.21k	1%	Ω	DC resistance
Line Inputs: Type	Active Balanced/Unbalanced			Right Input tied to Left Input when unplugged (Mono)
.....Connector	¼" TRS			Tip=(+); Ring =(-); sleeve ch. gnd.
.....Impedance (Stereo/Mono)	10k / 5k	2%	Ω	each leg, 1kHz
.....Maximum Input	21		dBu	Input Gain centered, 1 kHz sine
Aux Mic Input: Type	Active Balanced/Unbalanced			3-pin XLR-Female type, pin 2(+)
.....Impedance	1k	1%	Ω	each leg, 1 kHz
.....Maximum Input	-16, 1 kHz sine		dBu	Trim = min; Input Gain = center
.....Overload	-20	±1	dBu	
Input Gain Control: Range	-12 to +12	1	dB	
.....Center Gain	0	±0.5	dB	
.....Signal present	-50	max	dBFS	
.....Line Input: VU mode	-31	max	dBu	both channels 1 kHz sine
.....Line Input: RTA mode	-37	max	dBu	both channels 1 kHz sine
.....Aux Mic Input	-68	max	dBu	Trim = min; 1 kHz sine
.....Overload	-4	min	dBFS	
.....Line Input: VU mode	17	min	dBu	both channels 1 kHz sine
.....Line Input: RTA mode	11	min	dBu	both channels 1 kHz sine
.....Aux Mic Input	-20	min	dBu	Trim = min; 1 kHz sine
Pink Noise Output: Type	Active Unbalanced			¼" TRS
.....Impedance	302	1%	Ω	
.....Level	Off to +4		dBu	
Pink Noise: Type	Pseudorandom (average)			½ dB error
.....Pink Noise Period	167	typ.	sec.	
.....Crest Factor	4.9	typ.		
Real Time Analyzer: Type	30 bands, rms averaging			25 Hz to 20 kHz, ⅓-octave centers
.....Scale	±1, ±3, ±6 dB per row		dB	User selectable
.....Range (max/min)	40 (100 @ Gain -12 60 @ Gain +12)		dB SPL	Pink noise source, Cal Mic Input
.....Filters	4th-order, ⅓-octave			IEC 61260 Class 2
.....Averaging Time Constant	Variable			
VU meter: Type	rms averaging			
.....0 dB point	4		dBu	Input Gain set to center
	-10		dBV	Input Gain set to maximum
	16		dBu	Input Gain set to minimum
.....Range	-31.5 to +12		dB	re: 0 dB point
.....Resolution	1.5 per column		dB	Accurate within 1.5 dB
.....Attack	300		msec.	To reach 0 dB indication
.....Decay	700		msec.	To reach -20 dB indication
.....Peak Hold Attack	Instantaneous			
.....Peak Hold Decay	2	typ.	sec.	
SPL meter: Type	RMS averaging			
.....Range	51 to 120		dB SPL	Auto Ranging: 80, 100, 120 dB SPL
.....Resolution	1		dB	

.....Accuracy	±4		dB	Using Rane MIC 2 set to CAL
.....Weighting Filters	A- & C-weight			IEC-61672 Class 1, 20 Hz - 20 kHz
.....Averaging Time Constant	1000		msec.	IEC-61672 Time weighting S - Slow
Power Supply Requirement	18 VAC w/center tap	10%	Vrms	RS 1 (see data sheet)
.....Maximum Current	750		mA	Rms current from remote supply
Unit: Agency Listing				
.....120 VAC model	Class 2 Equipment			National Electrical Code
	UL			Exempt Class 2 equipment
	CSA			Exempt Class 2 equipment
.....230 VAC model	CE-EMC			EMC directive 89/336/EEC
	CE-Safety			Exempt per art. 1, LVD 73/23/EEC
Power Supply: Agency Listing				Class 2 equipment
.....120 VAC model	UL			File no. E88261
	CSA			File no. LR58948
.....230 VAC model	CE-EMC			EMC directive 89/336/EEC
	CE-Safety			LV directive 73/23/EEC
Unit: Construction	Steel			
.....Size	1.75"H x 19"W x 5.3"D (1U)			(4.4 cm x 48.3 cm x 13.3 cm)
.....Weight	4 lb			(1.8 kg)
Shipping: Size	4.25" x 20.3" x 13.75"			(11 cm x 52 cm x 35 cm)
.....Weight	9 lb			(4.1 kg)
<i>Note: 0 dBu=0.775 Vrms</i>				

Block Diagram

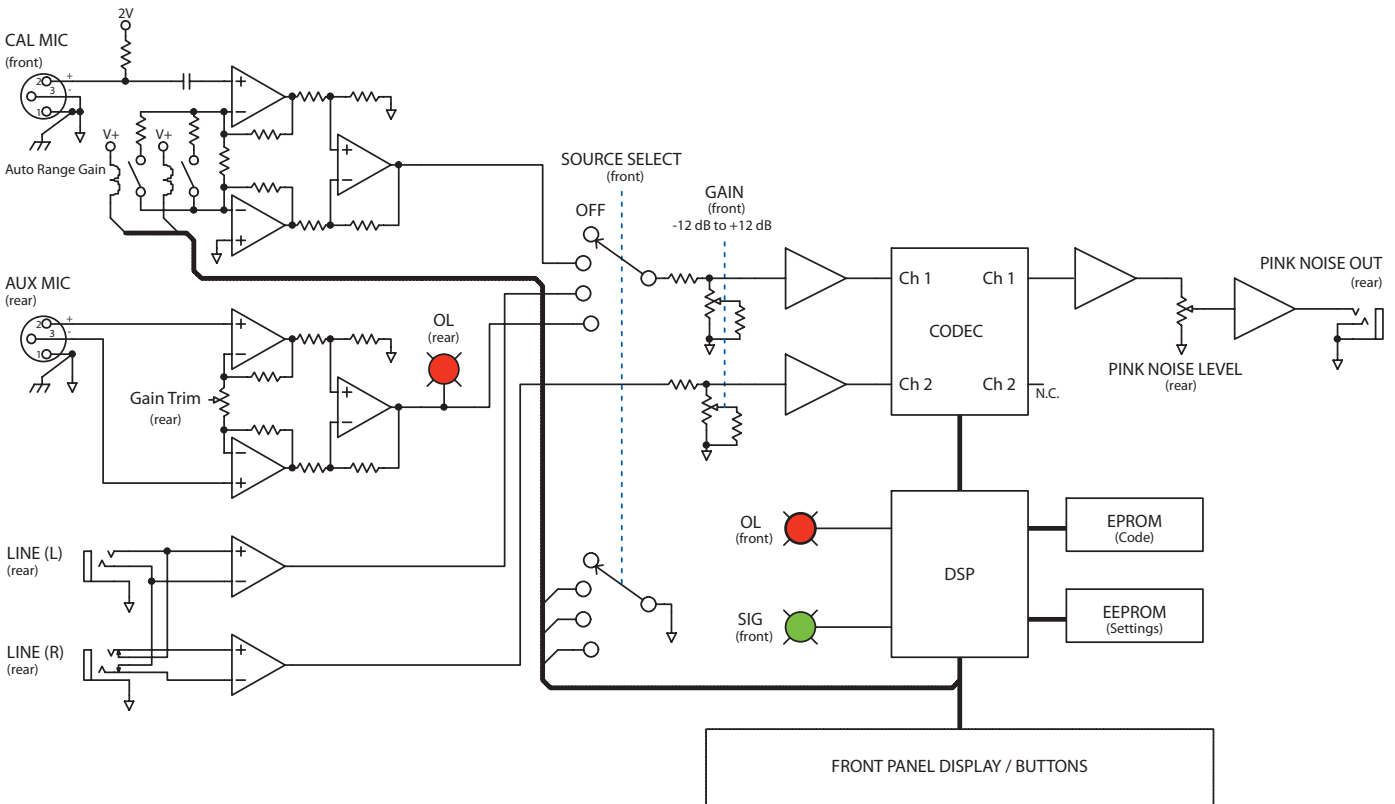

Rear Panel

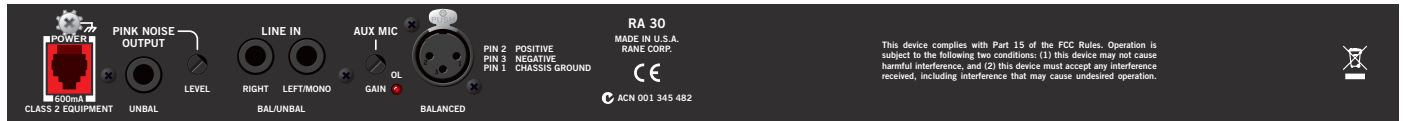

MIC 2 Details

The Rane MIC 2 Condenser Microphone is a professional quality back-electret condenser microphone with an omnidirectional pickup pattern. The MIC 2 uses the same element as Rane's MIC 1 which was sold with previous analyzers, but in a different casing.

The MIC 2 comes complete with a standard 25 foot (7.6 m) mic cable and clip to facilitate distant placement of the microphone from the analyzer. A zippered weather-resistant carrying/storage bag is included for added convenience and protection. The MIC 2 is housed in a brushed aluminum case.

Like all condenser microphones, the MIC 2 must be powered before operating. The RA 30 provides this power.

The MIC 2 is supplied with the RA 30 Realtime Analyzer. A replacement may be ordered separately at www.rane.com.



MIC 2 Specifications

Parameter	Specification	Limit	Units	Conditions/Comments
Microphone Type	Back-Electret Condenser			6 mm capsule
Frequency Response	20 to 16,000	1	dB	+2 dB at 20 kHz
Polar Pattern	Omnidirectional			
Impedance	1.8k	5%	Ω	With 2.2 k Ω load
Sensitivity	-44 (6.3 mV @ 94 dB SPL)	± 3	dB	re 0 dB=1V/Pa, 1 kHz 1 Pa = 94 dB SPL
Maximum SPL	140		dB	1 kHz
Signal-to-Noise Ratio	58 (re 94 dB SPL)	min	dB	1 kHz, A-weighted
Phasing	Non-inverting			Positive diaphragm pressure equals positive output voltage
Power: Voltage Range	1.5 to 6		VDC	T-power; absolute min and max ratings
.....Rated Voltage	2.0	10%	VDC	
.....Sensitivity Loss	-3 dB @ 1.5 VDC			
.....Current Demand	1	max	mA	@ 2.0 VDC
Cable	25 feet (7.6 meters)			2 conductor shielded; XLR-F to -M standard mic patch
Case	6" x 9" (15.2 cm x 22.9 cm)			Zippered heavy black vinyl
Storage Temperature	-20 to 60		$^{\circ}\text{C}$	-4 to 140 $^{\circ}\text{F}$
Operating Temperature	-18 to 50		$^{\circ}\text{C}$	0 to 122 $^{\circ}\text{F}$
Relative Humidity	0 to 95		%	Operating or storage

Architectural Specifications

The unit shall include functions of a realtime analyzer, sound pressure level meter, and stereo VU meter. The unit shall be contained in a rack mount chassis of one (1) rack space.

The RTA mode shall provide five LEDs for each of 30 bands using IEC 61260 class II filters covering 25 Hz to 20 kHz. User selectable 1, 3 & 6 dB RTA Scales shall be provided. A pink noise source with on/off button shall be provided. A normalize function shall set the 0 dB reference to the maximum band level.

The SPL meter mode shall include switchable A- or C-weighting filters. The maximum SPL shall be 120 dB.

The Stereo VU meter mode shall accept line-level inputs. The unit shall be able to calibrate to either +4 dBu or -10 dBV. The unit shall have a maximum VU of +12 dBu and a minimum VU of -31.5 dBu with a resolution of 1.5 dB. The VU meter shall provide an instant peak hold function with a 2 second hold time.

The unit shall have a front panel selector switch to choose the device input, including a calibrated microphone input, an auxiliary mic input, and left and right line inputs. The unit shall have input signal and overload indicators.

The unit shall have a built-in digital pseudorandom (pink noise) signal generator including a rear panel output and trim control, and a front panel on/off switch.

The unit shall come complete with an electret condenser microphone with a 25-foot cord packed in a carrying case.

The unit shall be capable of operation by means of an external power supply meeting CE requirements.

The unit shall be a Rane Corporation Model RA 30.