



Introduction to Speech Reinforcement with Conferencing

- **Controlling Acoustic Levels**
- **Calculating PAG and NAG**
- **Speech Reinforcement Zones**
- **Using Delays to Enhance the System**
- **The Haas Effect**
- **Noise Masking**
- **Feedback Eliminator**

Mike Slattery
Rane Corporation

RaneNote 140
© 1997 Rane Corporation

Introduction

Large conference rooms require speech reinforcement so people at all locations can adequately hear each other. To perform speech reinforcement without acoustic feedback is difficult, add Conferencing and it becomes complex. This RaneNote gives insight into acoustic proprieties of speech reinforcement and applications.

Controlling Acoustic Levels

The following operations neglect any effect of room echo or room acoustics.

Terms used for calculating properties:

D0 - Distance from talker to the farthest listener.

D1 - Distance from the source mic to the nearest loudspeaker.

D2 - Distance from the listener to the nearest loudspeaker.

Dn - Distance from the talker to the nearest listener.

Ds - Distance from the talker to the microphone.

NOM - Number of Open Mics

When audio travels from a source, its *Sound Pressure Level* (SPL) attenuates by half for every doubling of the distance. The formula for calculating the SPL attenuation is known as the inverse square law and is stated as:

Without speech reinforcement.

Inverse Square Law:

SPL Attenuation = **Dn** SPL - 20Log(**D0/Dn**)

When applying sound reinforcement to a large conference room, first you need to know the room's *Potential Acoustic Gain* (PAG). This allows you to determine the maximum amount of sound reinforced, in decibels, achievable before feedback occurs.

The PAG formula:

$$\text{PAG} = 20\text{Log}((\text{D0} * \text{D1}) / (\text{Ds} * \text{D2}))$$

If **NOM** is greater than 1 then:

$$\text{PAG} = 20\text{Log}((\text{D0} * \text{D1}) / (\text{D2} * \text{Ds})) - 10\text{LogNOM}$$

When using PAG to setup system gain, it is customary to add 6 dB of *Feedback Stability Margin* (FSM). Systems that operate at 6 dB below their PAG are usually free of feedback problems.

$$\text{PAG} = 20\text{Log}((\text{D0} * \text{D1}) / (\text{D2} * \text{Ds})) - 10\text{LogNOM} - 6 \text{ dB}$$

How much sound reinforcement is needed to achieve an average SPL at a distant listener's position relative to the non-reinforced SPL at a near listener's position?

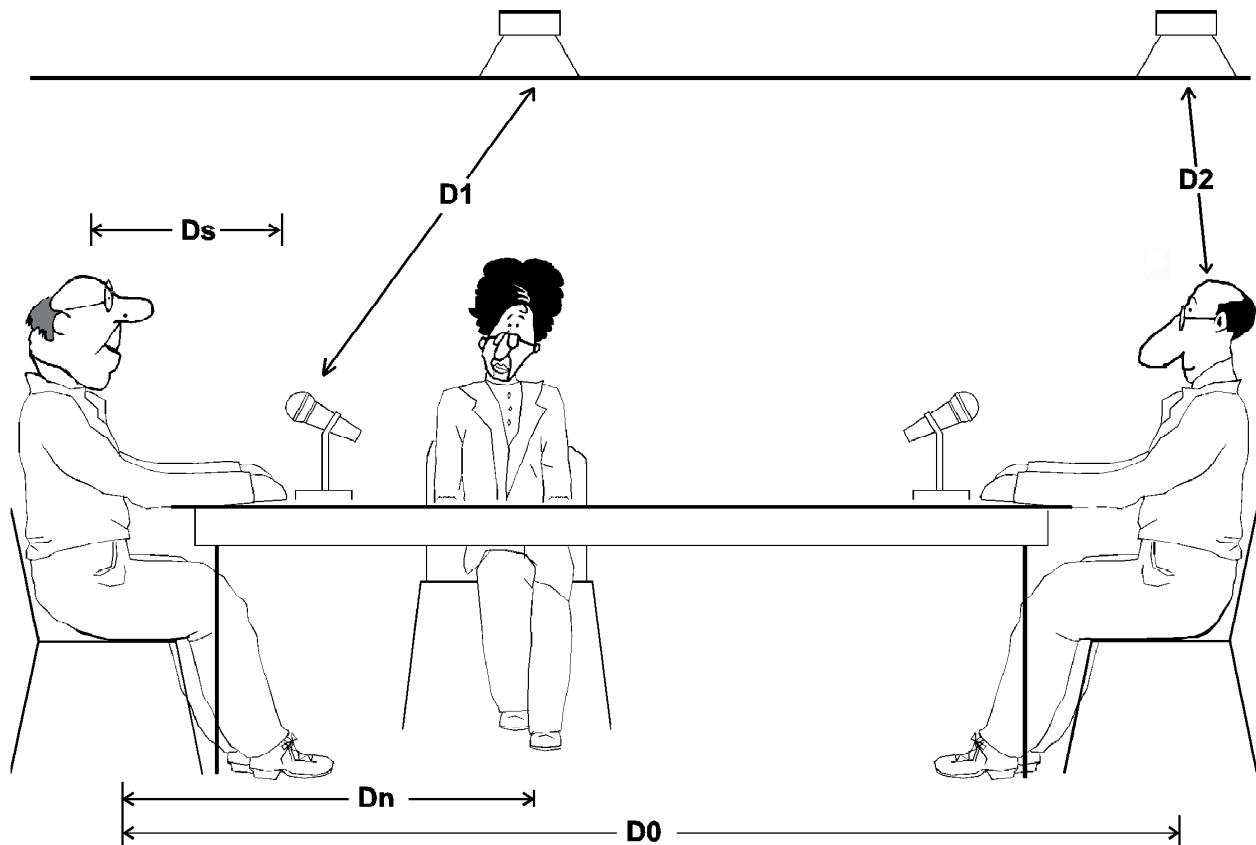

Figure 1. PAG and NAG

This *Needed Acoustical Gain* or NAG is the gain in decibels required by sound reinforcement to achieve an equivalent acoustic level at the farthest listener equal to what the nearest listener would hear without sound reinforcement.

The NAG formula: $NAG = 20\text{Log}(D0/Dn)$

NAG must be less than or equal to PAG to avoid feedback.

Example:

- D0** - 20 feet
- D1** - 10 feet
- D2** - 6 feet
- Dn** - 4 feet
- Ds** - 2 feet

Calculating PAG and NAG

Loudspeakers are placed throughout the conference room. The closest loudspeaker to the talker is placed 10 feet from the talker's microphone. The closest loudspeaker to the farthest listener is placed 6 feet from the listener.

1. How much acoustic gain can the sound system supply without causing feedback if only 1 microphone is on? (PAG)
2. How much acoustic gain is required for the farthest listener to hear at an equivalent level to the nearest listener? (NAG)
3. Can the farthest listener receive enough gain without feedback?

1. Using the PAG formula:

$$PAG = 20\text{Log}((D0 * D1)/(D2 * Ds)) - 10\text{Log}NOM - 6 \text{ dB}$$

$$PAG = 20\text{Log}((20*10)/(6*2)) - 6 \text{ dB}$$

$$PAG = 18 \text{ dB (to nearest whole dB)}$$

2. Using the NAG formula: $NAG = 20\text{Log}(D0/Dn)$

$$NAG = 20\text{Log}(20/4)$$

$$NAG = 14 \text{ dB}$$

3. Since PAG is the maximum calculated level that is obtainable without feedback and it is 4 dB greater than the calculated NAG level, the sound system should operate without feedback.

Speech Reinforcement Zones

To perform speech reinforcement in a large conference room or auditorium, it is best to use automatic microphone mixers and divide the room into zones. The zones are made up of both microphone and loudspeaker groups. A microphone group is a mix of the post-gate outputs from the individual microphones within a zone. Each loudspeaker group has its own amplifier to allow selective audio sources to be played within a zone. Grouping microphones within a zone allows a microphone group to be played at selected loudspeaker groups. Zoning allows microphones within a zone to be played on loudspeakers of other zones while disabling them from being played within their own zone. This is typically called a *mix-minus* zone system.

Some system designers use relays to disable a loudspeaker group when a microphone within its zone gates-on. *Use caution with this type of design with acoustic echo cancellers.* Changes in the acoustic properties of a room, caused by switching loudspeakers, will cause the echo canceller to lose its adaptation and return echo.

The simplest example of using zones for speech reinforcement uses only two zones, with each zone having

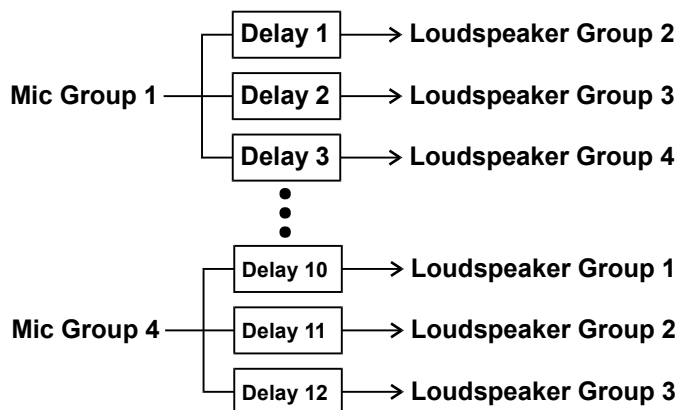
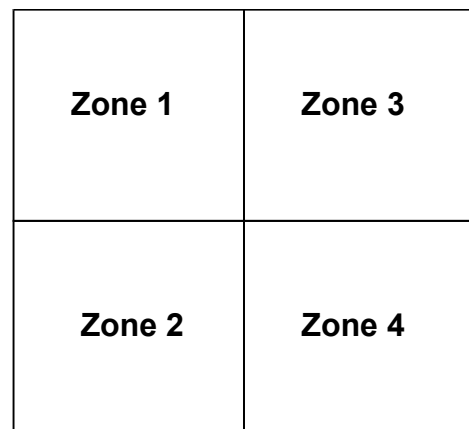

Figure 2. Delays

one microphone and one ceiling loudspeaker. A microphone and ceiling loudspeaker are placed at each end of a conference table. Zone 1 contains the left microphone and ceiling loudspeaker and Zone 2 contains the right microphone and ceiling loudspeaker. To perform speech reinforcement, Zone 1's microphone's audio signal is feed only to Zone 2's ceiling loudspeaker and Zone 2's microphone's audio signal is feed only to Zone 1's ceiling loudspeaker.

Using Delays to Enhance the System

Sound travels through 70 °F air at about 1.13 feet per millisecond. In a large conference room using speech reinforcement, this delay causes the listener to perceive the direction of the talker from the ceiling loudspeakers and not directly from the talker. This delay-related phenomena is one aspect of the *Haas Effect* or *precedence effect*.

The Haas Effect

When two loudspeakers are referenced with the same signal, the sound image direction is centered between the two loudspeakers. As one of the loudspeakers is delayed up to 10 milliseconds, the sound image direction is shifted towards the non-delayed loudspeaker. For the sound image to be restored to the center position, the delayed loudspeaker level must be increased by 10 dB. Increasing the level of the delayed loudspeaker also adds to the loudspeaker's SPL. If the delay is between 10 to 30 milliseconds, the delayed loudspeaker contributes a sense of liveliness but not direction. Increasing the delay by 50 milliseconds or more causes the listener to become aware of the delayed loudspeaker.

By utilizing the Haas Effect in a speech reinforcement system, the sound image direction is maintained from the talker and not the loudspeakers. This is achieved by using delays in the sound system to align each microphone group to its reinforcement zone. To determine the amount of delay required between each microphone group and its loudspeaker groups,

measure the distance from the center talker of one microphone group to each center listener of the zones that the talkers microphone is reinforced. Add to the measurement the distance from the listener to his closest loudspeaker. Using the measured distance for each zone, calculate the delay and add 10 milliseconds (See above formula). Apply the calculated delay time to each zone for the microphone group. *The number of delays required to perform this task is staggering for a large number of zones.* For example, a system with four zones may require three delays per zone (a delay for each microphone group within a zone) for a total of twelve delays!

Another method for aligning a microphone group to a zone is to use programmable delays for each zone and speech detection for each microphone group. For this to work, the programmable delay must have fast recallable memories without producing audio artifacts during delay changes. Each delay must have a memory setting stored for each microphone group. When speech is detected within a microphone group, all delays must recall their setting for that group.

Noise Masking

Providing a method for noise masking allows individuals to talk "off-record" without being easily heard by others in the room. This method is commonly used in courtroom applications. Since noise masking may need to be selected in different areas, use a matrix mixer to select the masked zones.

Feedback Eliminator

Installing feedback eliminators at each loudspeaker group can help maintain system stability by reducing feedback. The typical feedback eliminator performs this function using high-Q adaptable notch filters. When using feedback eliminators with echo cancellers, bypass the far-end audio around the feedback eliminator.

Reference

Glen M. Ballou, *Handbook for Sound Engineers Second Edition* (SAMS, 1991)