

Quick Start

How many knobs does it take to turn on eight green LEDs? One...but at least read this section to avoid unwelcome jokes.

Architectural look. Since Decora plates come in different colors, each SR 4 is shipped with 3 different color labels for installation behind the lens (we ship them without an insert installed). Colors included are white (w/ black logo), almond (w/ black logo) and black (w/ white logo) which accommodate most applications. The label has a transparent window so custom selection lists can be seen. Custom selection lists are easily created using a Microsoft Word™ template or the SR Label Maker application included on the Drag Net CD-ROM or downloadable from www.rane.com/sr4.html.

Address. Set the Device Address rotary switch on the side of the SR 4; addresses from 0 through 7 are valid. Each device connected to the same RS-485 bus must have a unique address.

Wiring. Use CAT 5 cable with a minimum of 2 twisted pairs to connect to the SR 4. The use of DOG 4 cable may cause random barking in high traffic areas (another joke, couldn't resist). Connect one twisted pair of wires to the “-V” and “+V” terminals – “-V” must connect to the power supply ground and “+V” must connect to +8 to +15 volts. Connect the second twisted pair of wires to the “A” and “B” terminals; “A” connects to the RS-485 “data +” connection and “B” connects to the RS-485 “data –” connection. When shielded CAT 5 cable is used, a chassis terminal is provided for shield termination.

Setup software. The SR 4 is configured using Drag Net software included in the box or available at www.rane.com/dragnet.html. See “Working with Smart Remotes” on page Manual-3.

Front Panel Description

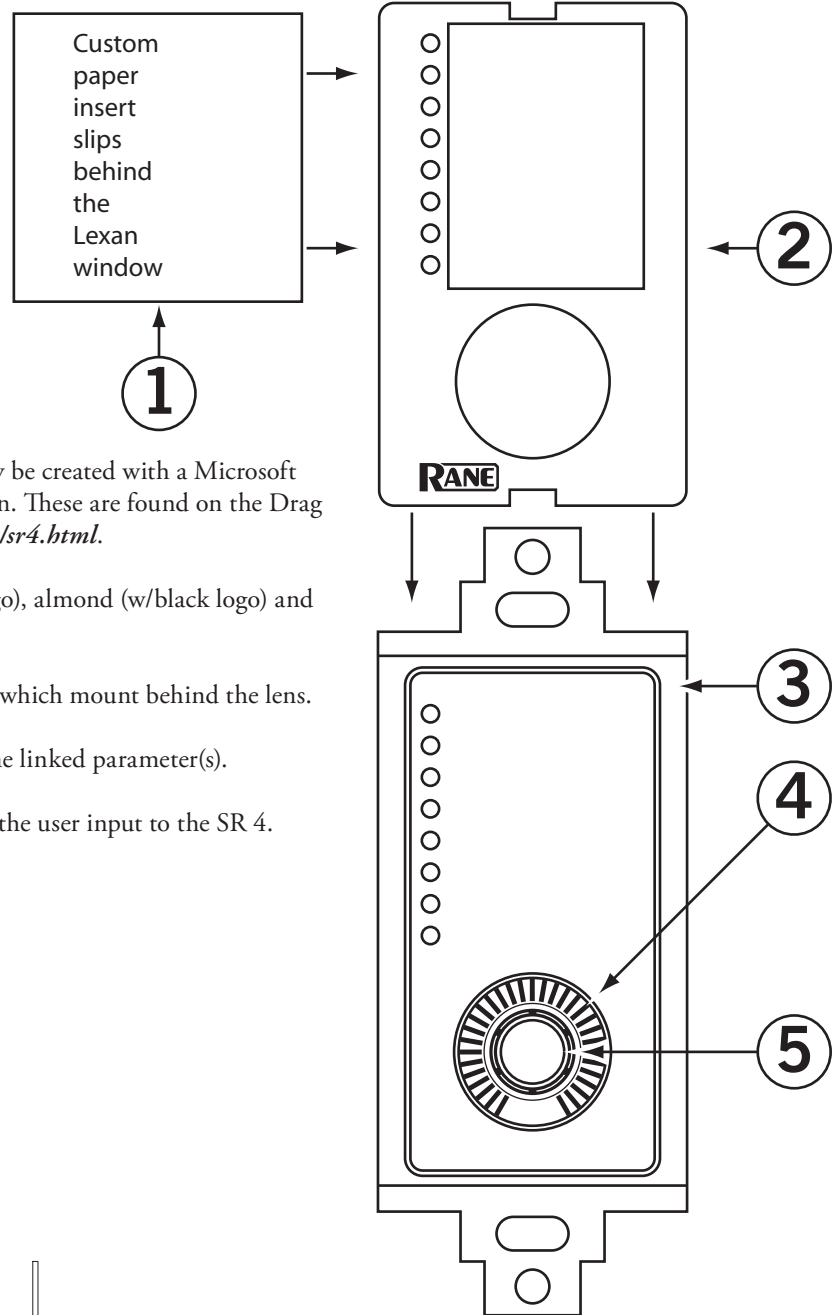

- ① **Paper insert** lays behind the Lexan label, and may be created with a Microsoft Word™ template or the SR Label Maker application. These are found on the Drag Net CD-ROM or downloadable at www.rane.com/sr4.html.
- ② **Lexan label** 3 colors included: white (w/black logo), almond (w/black logo) and black (w/white logo).
- ③ **Clear lens** helps support different color templates which mount behind the lens.
- ④ **LED indicators.** Indicate the current “level” of the linked parameter(s).
- ⑤ **Encoder Knob with momentary push switch** is the user input to the SR 4.

Rear Panel Description

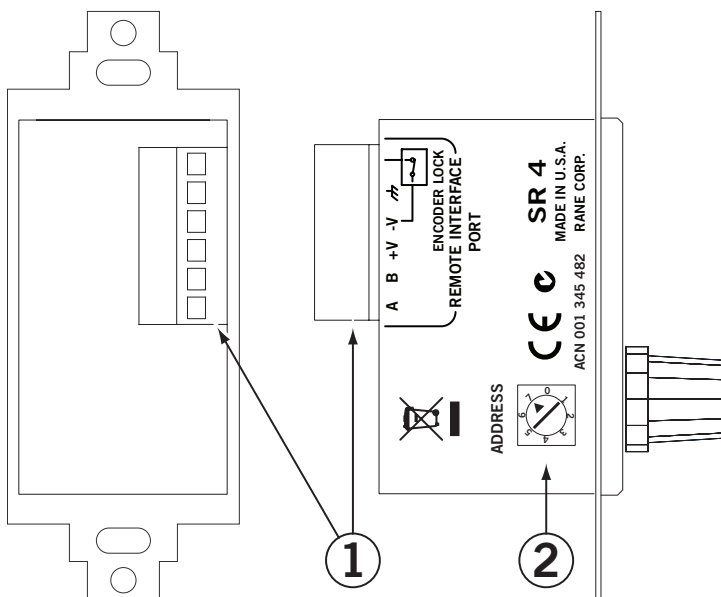

- ① **6-wire Euroblock connector.** Connects the SR 4 to a controller. **A** connects to RS-485 data +, **B** connects to RS-485 data -. **+V** is the positive side of the power supply rail. **-V** is the negative/ground side of the power supply rail. Ground is the connection point for the shield when shielded cable is used. When the Encoder Lock pin is grounded and Auto Lock is enabled, encoder input is ignored by the SR 4. This, for example, allows a keyed switch to be installed next to the SR 4 that allows the device to be “locked” so only keyholders can change system volume.
- ② **Device Address switch** to assign the device its RW 485 address. Addresses 0 through 7 are valid.

Working with Smart Remotes

Smart Remote Overview

Users familiar with Rane's SR Configurator program rejoice: Smart Remotes are now configured entirely within Drag Net 4.0! SR Configurator is no longer used and can be uninstalled, preferably with some kind of accompanying ritual or chant.

The following sections describe configuring the various parameters and modes for the remotes themselves. Details on assigning remotes to control parameters and functions with an RPM are found in Drag Net's included Help file (Help > Help Topics).

Creating a new Configuration

Smart Remote configurations can be created as offline Storage files, for subsequent transfer to a Live remote. To create a new Smart Remote Configuration:

1. Click the **File** menu, choose **New**, then select **Configuration** (CTRL + N).
- or - Click the **New Configuration** button in the standard  toolbar.
- or - Right-click within the Project window and select **New**, then **Configuration** (CTRL + N).
2. Select the configuration source, either from an empty configuration, or from an existing Rane- or User-defined template. Select a device type from the **Configuration Type** list to filter the list of file options (to only show SR 3 files in the User Template directory, for example). Selecting the **Copy Settings** check box copies all parameters to the new configuration. This is a particularly useful feature when creating new configurations based on existing User Templates.
3. Select a configuration type (SR 2, SR 3, SR 4) from the list of choices.
4. Click **Next**
5. Enter a Name, storage location on your hard drive, and brief description of the configuration.
6. Click **Finish** and start configuring the remote!

File extensions for Smart Remote configurations follow the remote type – SR 2 configurations are stored as .sr2 files, for example.

Each remote has a number of configuration parameters which determine basic functions and user operation modes. These parameters are stored locally on each remote in non-volatile memory.

SR 4 Configuration Parameters

The SR 4 features a 31-position LED indicator, rotary data encoder with integrated push switch, and a column of eight green LED indicators for selection status. Custom selection lists are easily created using the included Microsoft Word template or SR 4 Label Maker application. The printed list is then placed beneath the transparent window of the SR 4's faceplate insert, and held firmly in place by a plastic lens.

Auto Lock

Auto Lock is used in conjunction with the SR's Encoder Lock pin to disable the SR encoder. When the Encoder Lock pin is grounded and **Auto Lock** is enabled, changes in position of the encoder are ignored by the SR. For example, a keyed switch installed next to the SR allows the device to be locked temporarily so the system volume can not be adjusted.

Knob Turn

When **Auto Level** is enabled and the encoder is turned normally (without pushing it in) the LED moves clockwise or counterclockwise one position in the direction the knob was turned. Always enable **Auto Level** when using a Smart Remote with a Rane RPM device.

Knob Push & Turn

When **Auto Selection** is enabled and the encoder is held in and turned, the vertical selection LED moves vertically amongst the choices.

When **Selection Roll** is enabled the selection wraps around from last to first (or first to last, depending on the direction the encoder was turned).

When **Update on Release** is enabled, the SR updates its Selection index when the encoder is released, rather than updating each time the encoder is turned. This feature allows users to scroll through selections, choose the selection they want, then release the encoder to trigger the action (for example, recall a Preset on an RPM 88).

Knob Bump

When **Auto Selection** is enabled and the encoder is pressed in and released (without turning), the next Selection is automatically chosen; the Selection index is updated after the Update Timer expires. Note: Selections automatically roll from last to first while in Bump mode.

The **Update Timer** determines how long the SR 4 waits before updating its Selection index once the encoder is released. Setting this value to 0 updates the index instantly, with every press/release combination of the encoder. Increasing this value allows users to scroll through and preview selections without updating the index on every press. The valid range for the timer is 0 to 5 seconds.

Max Num Selections

Max Num Selections limits the number of selections accessible by the user. For example, if Max Num Selections is set to 4, the user is only able to access Selections 1 to 4, even though there are 4 other Selections (total of 8) stored on the SR 4. Max Num Selections only applies when an **Auto Selection** mode is enabled.

Polling for Remotes

Ethernet versus Serial Communication

If Smart Remotes are connected to an RPM device, the RPM acts as a data bridge, allowing communication with the remote through the Ethernet connection to the RPM. Smart Remotes appear beneath the RPM device in the Live folder of the Project window.

Serial communication takes place through the PC's COM port, which is usually RS-232 and therefore must be connected to the SR using an RS-232 (unbalanced data) to RS-485 (balanced data) converter capable of supporting the desired baud rate. Rane makes a suitable device - namely the DSC 1. Select the COM port connected to the SR from the list of available ports when polling for Live devices.

Baud Rate

The Baud Rate can only be set when Serial Mode is selected during polling. When configuring Remotes used with Rane controllers (i.e., RPM 88/44/22), the RW 485 baud rate of 38400 bps is automatically set. Should you encounter communication problems, settings can be restored to 38400 baud, 10 ms delay by holding the encoder in while powering the remote. Release the encoder when its LED lights.

Transferring Configurations to and from a Live Remote

Remotes can be configured offline in Storage mode, then transferred to a Live remote when you get to the job site. Alternately, you can transfer the contents of a Live remote to an offline Storage configuration as a backup, or for editing when you're back in the comfy chair at the office.

Storage to Live

Live remotes are initialized by transferring a Storage configuration to a Live remote. This action replaces all settings on the remote. Once the transfer is complete you can continue to work directly with the Live remote, adjusting mode parameters, inserting bitmaps (SR 3), and so on. Hint: You'll need to **Poll for Live devices** before transferring configurations. To transfer a Storage remote configuration to a Live device:

1. Toggle the Project Window on if it's not already visible (**View > Project**).
- 2a. Drag and drop the Storage configuration listed under the Storage folder onto a destination remote listed under the Live folder.
- or -- 2b. Select the Storage configuration, click the **Transfer Config To** button, and then select a destination remote from the list.
- or -- 2c. Right-click the Storage configuration and choose **Transfer To**, then select a destination remote from the list.

Live to Storage

Important: Transferring from a Live remote to an existing Storage configuration overwrites the Storage configuration.

To transfer from a Live remote to a Storage configuration:

1. Toggle the Project Window on if it's not already visible (View > Project).
- 2a. Drag and drop the Live remote onto an existing destination Storage configuration.
- or -- 2b. Select the **Live remote**, click the **Transfer Config To** button, and then select a destination Storage configuration from the list, or choose to create a new configuration.
- or -- 2c. Right-click the **Live remote** and choose **Transfer To**, then select the destination Storage configuration from the list, or choose to create a new configuration.

Editing a Live Remote

It is possible to edit any parameter on a Live remote directly, without first having to transfer a Storage configuration to it.

To view the current contents of a Live remote simply double-click the remote listed under the Live folder of the Project Window. Alternately, right-click the **Live remote** and choose **Open item**. The contents of the Live remote are then loaded into the Device Configuration window for viewing and/or editing.

Renaming a Remote

To rename a Smart Remote:

1. Right-click the **Live remote** in the Project window and choose Properties.
2. Enter a new name for the remote in the Name field.

Updating Smart Remote Firmware

It may be necessary to update a Smart Remote's firmware in order to add features or address one of those pesky glitches that only seem to appear after the product's been released.

Remotes with the following firmware versions can be upgraded as new firmware becomes available:

Remote	With Firmware Version
SR 2	2.0 and higher
SR 3	4.0 and higher
SR 4	1.0 and higher

Older remotes may not be updateable, or updateable only by Rane. Contact Rane Tech Support 425-355-6000 or visit www.rane.com for more information.

Firmware files for all remotes are installed as part of Drag Net and are located in the Program Files\Rane Corporation\Drag Net\Firmware\Smart Remotes directory.

To update firmware in a Smart Remote:

1. Ensure remotes are properly connected to the RPM device. Remotes must be connected before powering the RPM on.
2. Connect directly to the RPM device, using an Ethernet cross-over cable.
3. Poll to find the Live device. Remotes are listed beneath the RPM device in the Project window.
4. Select the Remote to be updated.
5. Launch the **Update Device Firmware Wizard** (Tools > Update Device Firmware).
6. Follow the wizard's on-screen instructions to complete the operation. The device automatically resets itself once the update is complete.

Firmware updates performed using a COM Port (Serial) follow the exact same steps, beginning with Step 3.

SR 4 Wiring Guidelines

Restrictions

24 AWG CAT 5 cable resistance = 26 ohms per 1,000 feet. There are two wiring restrictions. First, RW 485 has a maximum of 1,000 feet. The total length may not exceed this limit in any combination of series or parallel runs.

Second, the voltage of the power supply also affects the maximum distance of each length between, and the number of Remotes. Refer to the tables on the following pages depending on which wire, voltage, number of Remotes, and if you are using single or multiple runs.

External Power Supply

The RPM 88's RW 485 port does not offer enough current to power more than six SR 4 remotes — an external DC supply must be used. Rane recommends using a 12 to 15 volt DC regulated power supply capable of delivering a minimum of 1 amp of current. The combined current draw on the RPM 88's RW 485 port and VOP cannot exceed 375 milliamps. [The RPM 44 and RPM 22, however, can power up to eight SR 4 remotes.]

Most installations will have a mix of SR 2, SR 3, and SR 4 remotes each with their own current requirements. To make calculation easy as to whether or not an external supply is necessary, a Microsoft Excel™ spreadsheet is available named SRXCABLELENGTH.XLS. This file is on the Drag Net CD-ROM, or downloadable from www.rane.com/sr2.html.

If you have a Radio Shack nearby, they offer a 15 volt 1 amp supply, catalog number: 273-1691. To ease installation, use a 6 foot Adaptaplug extension cable, Radio Shack catalog number 273-1641.

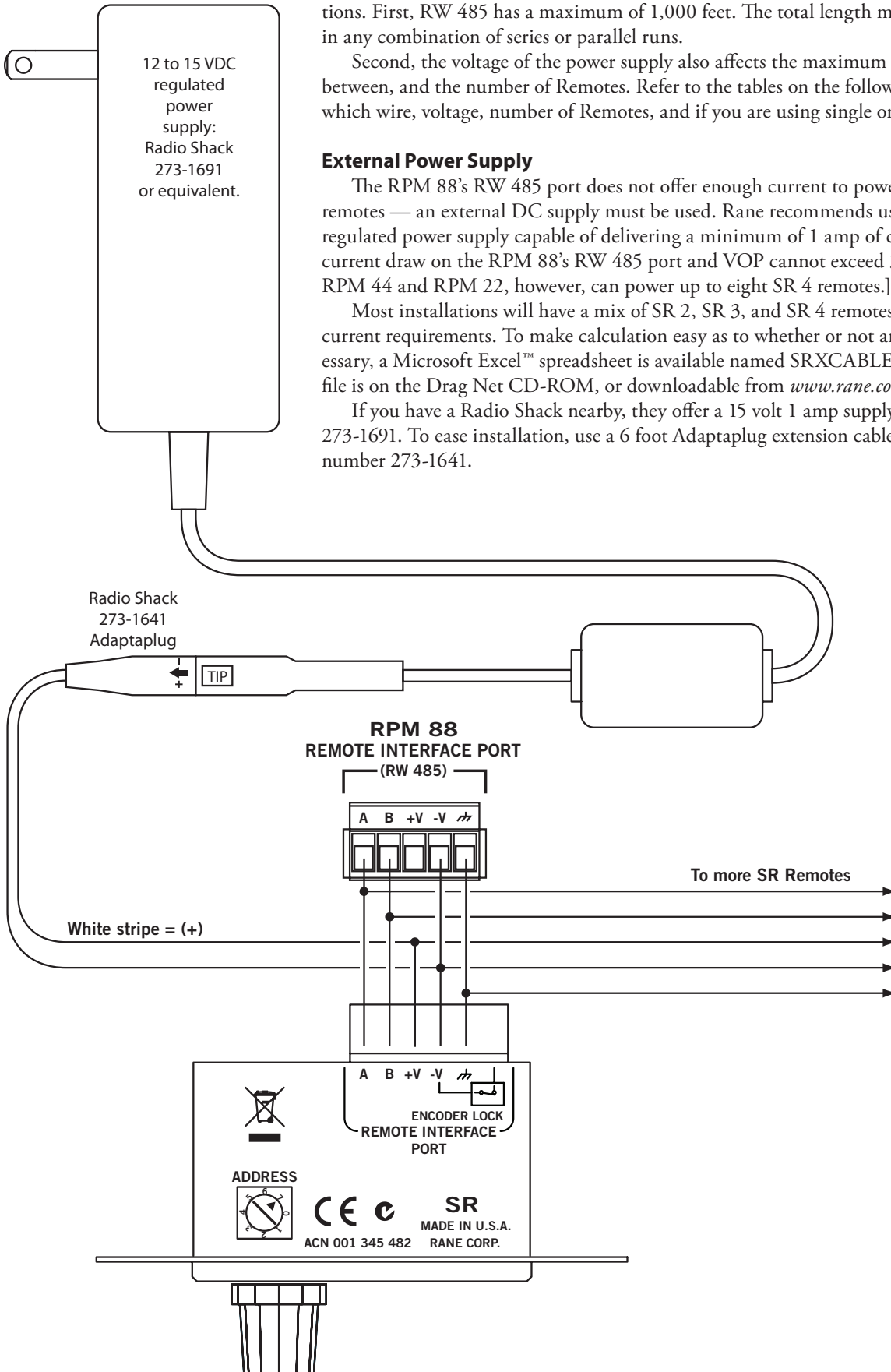

Cable Type 1

2 twisted pair unshielded CAT 5, Belden #1588(A,R)

2 twisted pair unshielded CAT 5, Belden #1590A

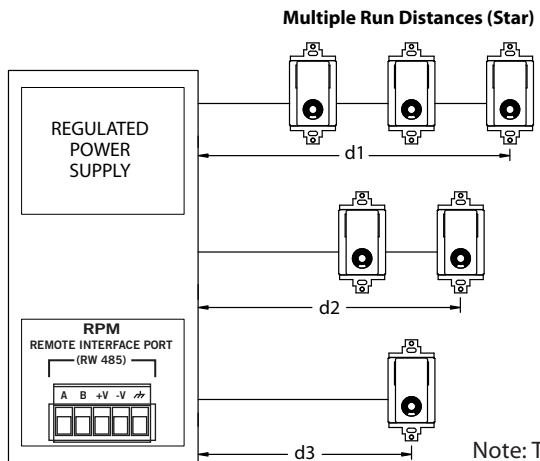
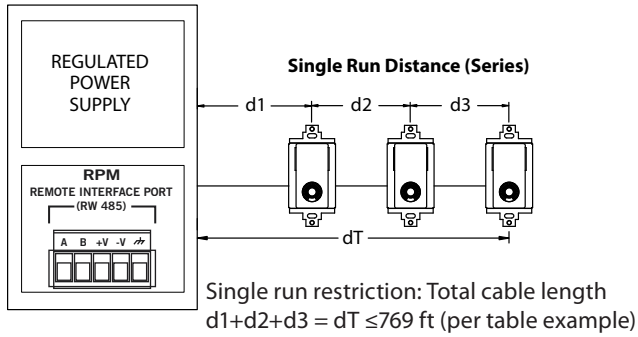

	Max Distance for Cable (feet)	Max Distance for Cable (meters)	Number of SR 4 Remotes
Vs = 15V RPM 44 RPM 22	1000	305	1
	1000	305	2
	769	235	3
	599	183	4
	490	149	5
	415	126	6
	359	110	7
	317	97	8

Vs = 12V RPM 88	1000	305	1
	672	205	2
	481	147	3
	374	114	4
	306	93	5
	259	79	6
	225	68	7
	198	60	8

Requires external supply

Vs = 8V	224	68	1
	134	41	2
	96	29	3
	75	23	4
	61	19	5
	52	16	6
	45	14	7
	40	12	8

Note: This table is *only* for systems using SR 4 remotes (all remotes on 485 bus are the same). For mix and match calculation of SR 2, SR 3 and SR 4 Remotes, use the SRCABLELENGTH.XLS Microsoft Excel™ spreadsheet on the Drag Net CD-ROM or at www.rane.com/sr4.html.

Multiple run restriction (per table entries): $d1 \leq 769$ ft, $d2 \leq 1,000$ ft, $d3 \leq 1,000$ ft
Total cable length must be under 1,000 ft: $d1 + d2 + d3 = dT \leq 1,000$ ft

Examples:

So if

$d1=400$ ft (<769 ft, OK)

$d2=300$ ft (<1,000 ft, OK)

$d3=200$ ft (<1,000 ft, OK)

$d1+d2+d3=900$ ft, then it's all OK!

but if

$d1=500$ ft (<769 ft, OK)

$d2=400$ ft (<1,000 ft, OK)

$d3=300$ ft (<1,000 ft, OK)

$d1+d2+d3=1,200$ ft, then it's NOT OK!

RPM
REMOTE INTERFACE PORT
(RW 485)

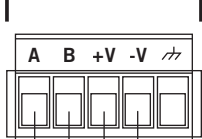

BELDEN #1588 (A,R)
BELDEN #1590 (A)

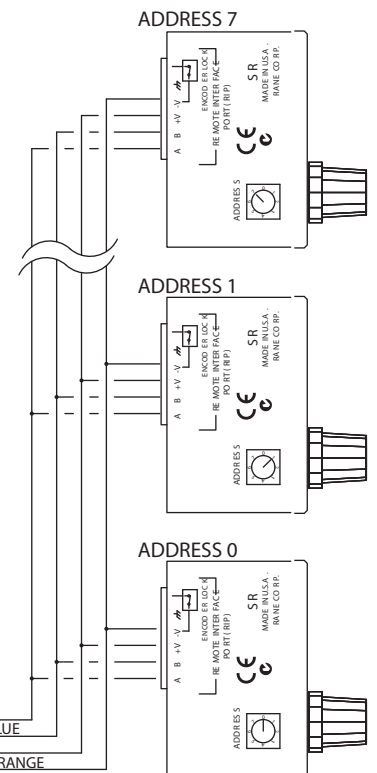
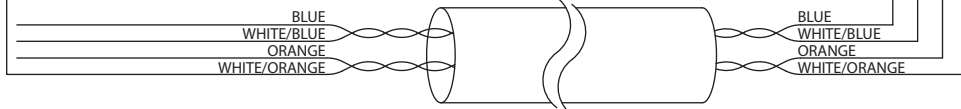

Cable Type 2

4 twisted pair unshielded CAT 5, Belden #1583(A, B, E, ENH, R)

4 twisted pair shielded CAT 5, Belden #1624 (P, R)

4 twisted pair unshielded CAT 5, Belden #1700 (A, R)

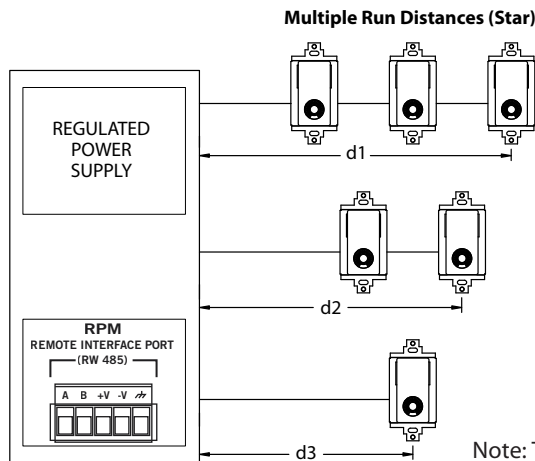
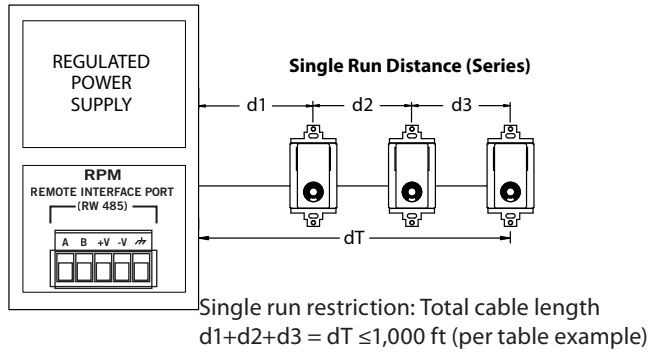

	Max Distance for Cable (feet)	Max Distance for Cable (meters)	Number of SR 4 Remotes
Vs = 15V RPM 44 RPM 22	1000	305	1
	1000	305	2
	1000	305	3
	1000	305	4
	1000	305	5
	1000	305	6
	1000	305	7
	952	290	8

Vs = 12V RPM 88	1000	305	1
	1000	305	2
	1000	305	3
	1000	305	4
	919	280	5
	778	237	6
	674	205	7
	595	181	8

Requires external supply

Vs = 8V	671	205	1
	403	123	2
	288	88	3
	224	68	4
	184	56	5
	156	47	6
	135	41	7
	119	36	8

Note: This table is **only** for systems using SR 4 remotes (all remotes on 485 bus are the same). For mix and match calculation of SR 2, SR 3 and SR 4 Remotes, use the SRCABLELENGTH.XLS Microsoft Excel™ spreadsheet on the Drag Net CD-ROM or at www.rane.com/sr4.html.

More conductors mean greater operating distance.

Multiple run restriction (per table entries): $d1 \leq 1,000$ ft, $d2 \leq 1,000$ ft, $d3 \leq 1,000$ ft

Total cable length must be under 1,000 ft: $d1 + d2 + d3 = dT \leq 1,000$ ft

Examples:

So if

$d1=400$ ft (<1,000 ft, OK)

$d2=300$ ft (<1,000 ft, OK)

$d3=200$ ft (<1,000 ft, OK)

$d1+d2+d3=900$ ft, then it's all OK!

but if

$d1=500$ ft (<1,000 ft, OK)

$d2=400$ ft (<1,000 ft, OK)

$d3=300$ ft (<1,000 ft, OK)

$d1+d2+d3=1,200$ ft, then it's NOT OK!

RPM
REMOTE INTERFACE PORT
(RW 485)

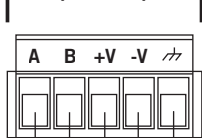

BELDEN #1583 (A, B, E, ENH, R)
BELDEN #1624 (P, R) *Shielded
BELDEN #1700 (A, R)

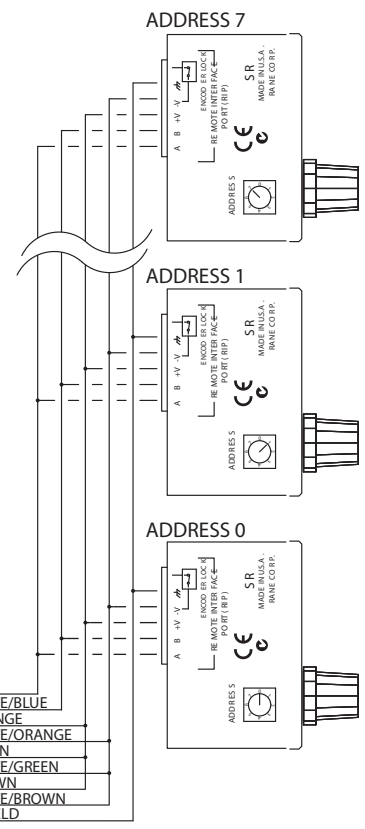
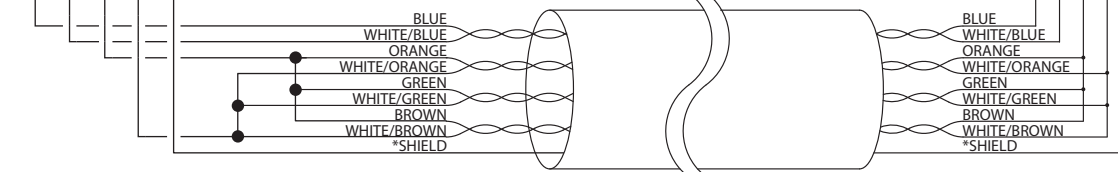

DSC 1

This page illustrates connection of a computer running Drag Net or a controller to SR 4(s) via RS-232 using the Rane DSC 1 (plus external power).

Note, earlier versions of the DSC 1 do not support the faster baud rates of the SR 4. DSC 1's with date codes later than 4/2001 should be used to guarantee carefree communications. The date code is found on the bottom of the DSC 1.

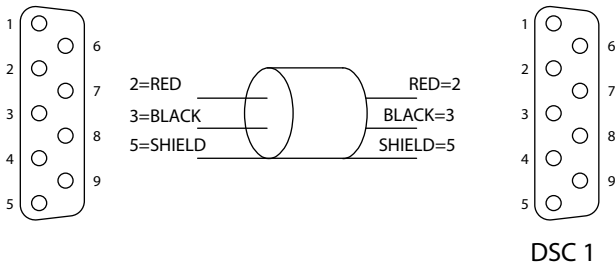

DB-9 male to DB-9 female

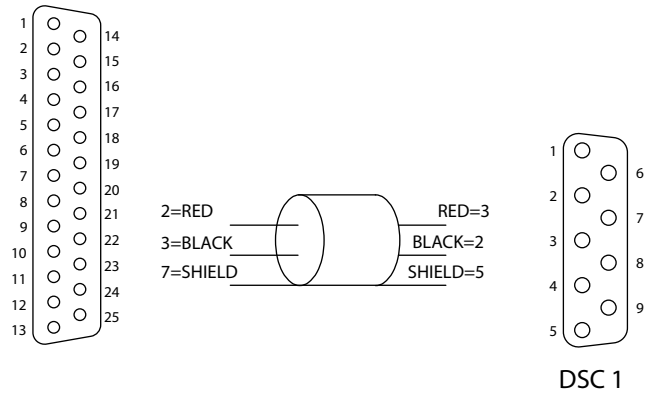

DB-25 male to DB-9 female

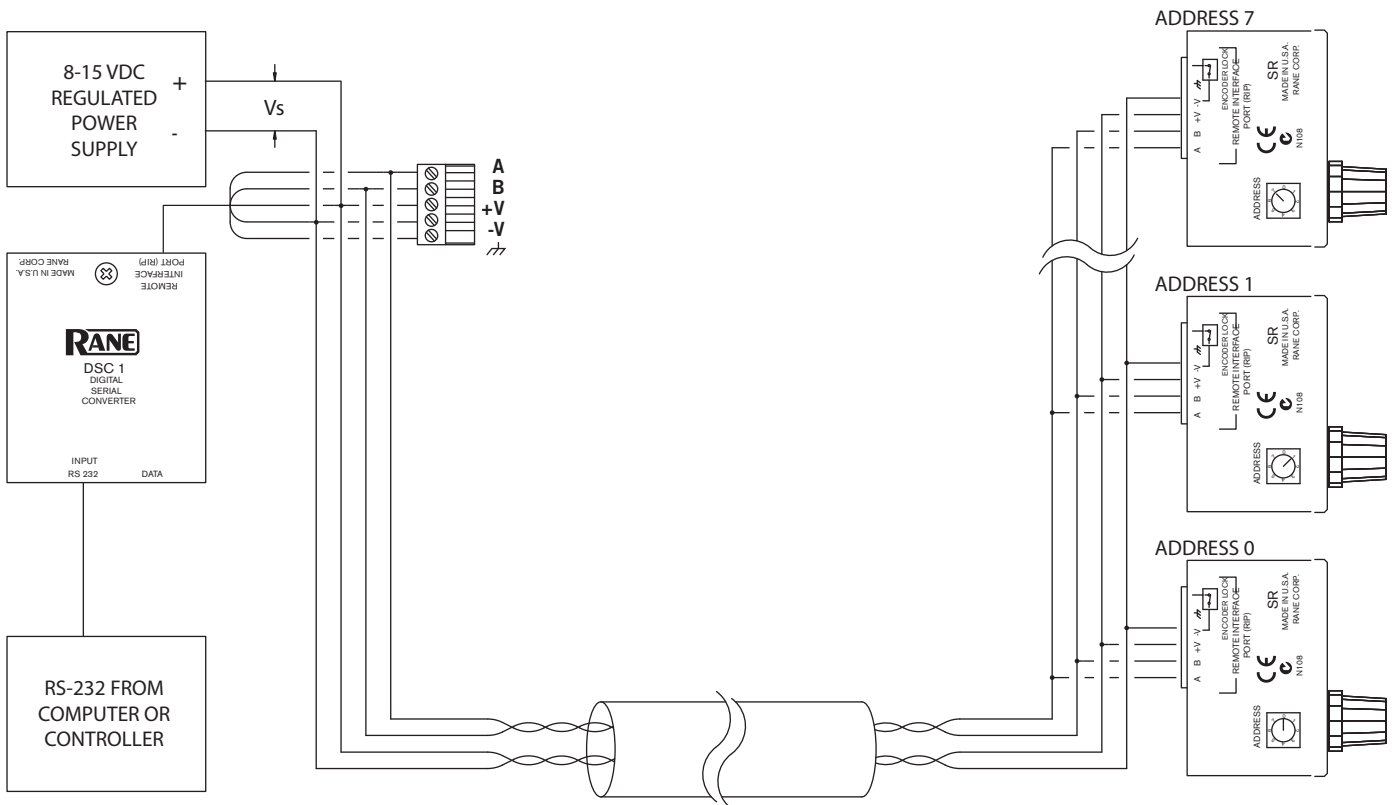

SR 4 Communication Protocol

The SR 4 communication protocol follows Rane's RW 485 specification. The following describes the SR 4 implementation.

Physical

The baud rate is 38,400 bps with No parity, 8 Data Bits, 1 Stop Bit (N81) format. The SR 4 also supports 9600, 19200, 57600, and 115200 bps. When configuring Remotes used with Rane controllers (RPM 22, 44, 88), the RW 485 baud rate of 38400 bps is required. At the end of a command message, the Master must release the bus within 10 ms. The SR 4 waits this length of time before transmitting its response. To restore the SR 4 communication settings to 38400 baud 10 ms delay, apply power while pushing the encoder *in* for several seconds until the encoder LED illuminates.

Master/Slave

RW 485 is a master/slave bus network, with only one master in charge, which we define as the Protocol Master (controller). When the Protocol Master expects a response from a slave, it relinquishes control of the bus, allowing the slave to drive the RS-485 bus. The slave must then release the bus back to the Protocol Master, and we start again. The SR 4 is always a slave.

Value Encoding

All numeric values are represented in ASCII decimal format separated by commas. Values with the MSB set (\$80 or larger) are interpreted as potential device addresses.

Syntax

Command messages are sent from the Protocol Master to the SR 4. Response messages are returned to the Protocol Master from the SR 4. The SR 4 always responds to the Protocol Master upon receiving a complete command message at the correct baud rate.

Command and response messages have the same format:

message = <addr> <msgtype> <devtype> <checksum> <command/data> <CR>

<addr> Each device has a unique address in the range [0, 7]. The encoding is one byte with the MSB set.

For example, if the SR 4's address switch is set to 5, the controller would send 10000101. (\$5 + \$80)

The SR 4 always returns its address switch setting plus \$80. (\$addr + \$80)

The address switch must be set in the range [0, 7].

<msgtype> The msgtype is a one byte set of flags indicating options, bit 7=MSB:

- bit 0) set = checksum is valid
- bit 1) set = there has been an error (response only)
- bit 2-5) reserved, cleared to 0
- bit 6) always 1
- bit 7) always 0

If the controller wants the SR 4 to verify the checksum, it would send a value of \$41, or an ASCII 'A'. If the controller wants the SR 4 to ignore the checksum, it would send a value of \$40, or an ASCII '@'.

The SR 4 echoes back the **<msgtype>** it was sent. In the case of an error, the SR 4 sets bit 1.

<devtype> The SR 4 device type value is \$33, or an ASCII '3'. The SR 4 also accepts a value of \$30, or an ASCII '0', the universal device type used for polling.

The SR 4 always returns its device type of \$33.

<checksum> The checksum is defined as the sum of the ASCII encoded values of the **<command/data>** section. The sum is then masked with \$007F to produce one byte with the MSB set to zero.

The controller would send a valid checksum as defined above if it sent a value of \$41 for the **<msgtype>**. The SR 4 then verifies the sent checksum by calculating the checksum from the data it received in the **<command/data>** section of the sent message. On the other hand, if the controller sent a value of \$40 for the **<msgtype>** the SR 4 ignores the sent checksum. The controller must always send a checksum less than or equal to \$7F, even if it intends for the SR 4 to ignore it.

The SR 4 **<checksum>** response is based on the **<msgtype>** it was sent. If the SR 4 received a **<msgtype>** of \$41, it returns a valid checksum (as defined) calculated from its response data. If the SR 4 received a **<msgtype>** of \$40, it returns zero.

<command/data> The general format is <cmd1,arg1,arg2,...,cmd2,arg1,...>. The commas are part of the <command/data> structure and act as delimiters between the ASCII encoded commands and data. Concatenation of commands is limited to four commands. Text string arguments are delimited with quotes ("String"). If the string argument contains quotes, an accent character (´) placed in the string argument will be interpreted by the SR 4 as a double quote character ("). The ASCII value for the accent character is \$60, not to be confused with a single quote character ('), ASCII value \$27. For example: string argument: "A string that contains 'quotes' " is interpreted as: A string that contains "quotes".

The controller sends commands/arguments for the SR 4 to process. This section of the message is limited to 40 characters for the SR 4. See the SR 4 Command Set section for details of valid commands.

The SR 4 responds with response data based on the commands/arguments it was sent. The SR 4 limits its response data to 40 characters. In the case of an error, the response data is: n,"ERROR" where n is an error code defined below:

Hex	ASCII	Error Code Meaning
\$31	'1'	Sent <devtype> invalid.
\$32	'2'	Sent <checksum> did not verify.
\$33	'3'	Sent <command/data> parse error.
\$34	'4'	Sent <command/data> greater than 40 characters, or the number of concatenated commands >4.
\$35	'5'	Response <command/data> greater than 40 characters.

See the **SR 4 Command Set** section below for details of valid SR 4 responses.

<CR> A carriage return (\$0D) terminates every message.

SR 4 Command Set

This section details the <command/data> portion of a complete RW 485 message. The SR 4 supports 10 commands. Below is a table of commands and associated responses, followed by descriptions.

Configuration Commands

Cmd	Arg(s)*	Description	Response**
V		Get Firmware, Hardware Version	n1,n2,"OK"
N	["ccc..."]	Read/Write Device's Name	"ccc...","OK"
SPL	n1[,n2]	Read/Write Stored Parameter	n,"OK"

Input Commands

ILD	[n1]	Read/Write LED Enable	n1,"OK"
ILK	[n1]	Read/Write Input Lock	n1,"OK"
IQ		Input Query	n1,n2,"OK"
IR		Input Raw	n1,n2,n3,n4,"OK"
IS	n1,n2	Input Suggest	n1,n2,"OK"
ISR	n1,n2	Input Suggest Raw	n1,n2,n3,n4,"OK"
IF	n1,n2	Input Force	"OK"

* [] denotes optional Command Argument

** Responses from concatenated commands produce only one "OK"

Configuration Commands

V

Get Firmware, Hardware Version

Send: V

Response: n1,n2,"OK"

Where: n1 is a two digit ASCII encoded decimal value representation of the firmware version. The first digit is the major firmware version and the second digit is the minor firmware version.

n2 is a one digit ASCII encoded decimal value representation of the hardware version.

Example: 13,2,"OK" means firmware version 1.3, hardware version 2.

N

Read/Write Device's Name

The device's name is limited to 32 characters and is stored in non-volatile memory. The default name is SR 4.

To read the device's name:

Send: N

Response: "ccc","OK"

Where: ccc is the device's name.

Example: "SR 4","OK" means the device's name is SR 4

To write a new name to the device:

Send: N,"ccc"

Where: ccc is the new name.

Example: N,"Conference Room 101" will rename the device to Conference Room 101

Response: "OK"

SPL

Read/Write Stored Parameter

Various configuration parameters are stored in non-volatile memory. This command reads and writes these parameters. For details of each parameter, see the **Stored Parameter List** section following the **Command Set** section.

To read a stored parameter value:

Send: SPL,n1

Where: n1 is the stored parameter index.

Example: SPL, 1 indexes the first parameter in the list which is the Auto Level parameter.

Response: n1,"OK"

Where: n1 is the value of the indexed parameter.

Example: 1,"OK" means that Auto Level is enabled.

To write a stored parameter value:

Send: SPL,n1,n2

Where: n1 is the stored parameter index.

n2 is the value to be stored.

Example: SPL,1,0 sets Auto Level parameter to 0, disabling the Auto Level function.

Response: "OK"

Encoder Input Commands

ILD

Read/Write Encoder LED Enable byte
Reads or writes the Encoder LED Enable byte.
To read the LED Enable byte:

Send: ILD
Response: n1,"OK"
Where: n1 is the Encoder LED Enable byte. The range is [0, 1].
Example: 1,"OK" means that the level LED indication is enabled.

To write the LED Enable byte:

Send: ILD,n1
Where: n1 is the Encoder LED Enable byte. The range is [0, 1].
Example: ILD,0 disables LED indication.
Response: "OK"

ILK

Read/Write Software Input Lock
Reads or writes the input encoder software lock byte. The format of the lock byte is as follows: bit 0 set locks the level (no action when encoder is turned), bit 1 set locks the selection (no action when the encoder is pushed in and turned), bit 2 set locks the enter state (no enter command state change when the encoder is pushed and released without turning). This lock byte is volatile, meaning upon power up of the device the software lock byte is always cleared to zero.

To read the Software Input Lock byte:

Send: ILK
Response: n1,"OK"
Where: n1 is the Software Input Lock byte. The lock byte range is [0, 7].
Example: 3,"OK" means that both the level and selection are locked.

To write the Software Input Lock status:

Send: ILK,n1
Where: n1 is the Software Input Lock byte. The lock byte range is [0, 7].
Example: ILK,2 locks the selection.
Response: "OK"

IQ

Input Query
Returns the current level and selection. Resets the command state to No Operation.

Send: IQ
Response: n1,n2,"OK"
Where: n1 is the current level. The level range is [1, 31].
n2 is the current selection. The selection range is [1, 8].
Example: 15,4, "OK" means that the current level is 15 and the current selection is 4.

IR

Input Raw
Returns the current level, selection, command state, and the length of time the encoder button has been pressed. Resets the command state to No Operation.

Send: IR
Response: n1,n2,n3,n4,"OK"
Where: n1 is the current level. The level range is [1, 31].
n2 is the current selection. The selection range is [1, 8].
n3 is the current command state. The command state represents the state of the encoder.

The possible states follow:

0	No Operation	The encoder has not changed.
1	Encoder Left	The encoder has been turned counter clockwise.
2	Encoder Right	The encoder has been turned clockwise
16	Selection Left	The encoder has been pushed in and turned counter clockwise.
32	Selection Right	The encoder has been pushed in and turned clockwise.
64	Enter	The encoder has been pushed in and released without being turned.

n4 is the length of time the encoder button has been pressed. The time the button has been pressed is in units of .01 seconds and the range is [0, 255] or 0 to 2.55 seconds. The button timer starts at the press of the button and is reset to zero when the button is released.

Example: 1,2,32,100,"OK" means the current level is 1, the current selection is 2, the current command state byte is a Selection Right and the button has been held in for 1 second.

IS

Input Suggest

Suggests new level and selection. Resets the command state to No Operation.

If Auto Level is enabled, the level is updated and indicated by the encoder LED only if the device's level has not changed by someone turning the encoder. Otherwise, if Auto Level is disabled, the level is updated and indicated by the encoder LED regardless of encoder input.

If either Auto Selection is enabled ("knob push and turn" or "knob bump"), the selection is updated and indicated by the column of LEDs only if the device's selection has not changed by local encoder action. Otherwise, if neither Auto Selection is enabled, the selection is updated and indicated regardless of encoder input.

Send: IS,n1,n2

Where: n1 is the suggested new level. The level range is [0, 31]. If n1 is zero, the level remains unchanged.

n2 is the suggested new selection. The selection range is [0, 8]. If n2 is zero, the selection remains unchanged.

Example: IS,3,5 suggests a new level of 3 and a new selection of 5.

Response: n1,n2,"OK"

Where: n1 is the current level. The level range is [1, 31].

n2 is the current selection. The selection range is [1, 8].

Example: 3,5,"OK" means the current level is 3 and the current selection is 5. This means the suggested level and selection were updated. A response of 10,5,"OK" means the current level is 10 and was last changed by someone turning the encoder and the current selection was updated to 5.

ISR

Input Suggest Raw

Same operation as IS Input Suggest except ISR returns the command state byte and button time. Suggests new main level and second level. Resets the command state to No Operation.

If Auto Level is enabled, the level is updated and indicated by the encoder LED only if the device's level has not changed by someone turning the encoder. Otherwise, if Auto Level is disabled, the level is updated and indicated by the encoder LED regardless of encoder input.

If either Auto Selection is enabled ("knob push and turn" or "knob bump"), the selection is updated and indicated by the column of LEDs only if the device's selection has not changed by local encoder action. Otherwise, if neither Auto Selection is enabled, the selection is updated and indicated regardless of encoder input.

Send: ISR,n1,n2

Where: n1 is the suggested new level. The level range is [0, 31]. If n1 is zero, the level remains unchanged.

n2 is the suggested new selection. Selection range is [0, 8]. If n2 is zero, the selection remains unchanged.

Example: ISR,3,5 suggests a new level of 3 and a new selection of 5.

Response: n1,n2,n3,n4,"OK"

Where: n1 is the current level. The level range is [1, 31].

n2 is the current selection. The selection range is [1, 8].

n3 is the current command state. The command state represents the state of the encoder.

The possible states follow:

0	No Operation	The encoder has not changed.
1	Encoder Left	The encoder has been turned counter clockwise.
2	Encoder Right	The encoder has been turned clockwise.
16	Selection Left	The encoder has been pushed in and turned counter clockwise.
32	Selection Right	The encoder has been pushed in and turned clockwise.
64	Enter	The encoder has been pushed in and released without being turned.

n4 is the length of time the encoder button has been pressed. The time the button has been pressed is in units of .01 seconds and the range is [0, 255] or 0 to 2.55 seconds. The button timer starts at the press of the button and is reset to zero when the button is released.

Example: 3,5,0,"OK" means the current level is 3, the current selection is 5, the current command state byte is a

No Operation and the button is not pushed in. This means the level and selection were updated. A response of

3,7,32,100,"OK" means the current level was updated to 3, the current selection is 7 and was last changed by someone

pushing in and turning the encoder, the current command state byte is a Selection Right, and a non-zero button time means someone is still holding the button in.

IF

Input Force

Forces new level and selection. Resets the command state to No Operation.

The level is updated and indicated by the encoder LED regardless of Auto Level configuration.

The selection is updated and indicated by the column of LEDs regardless of Auto Selection configuration.

Send: IF,n1,n2

Where: n1 is the new level. The level range is [0, 31]. If n1 is zero, the level remains unchanged.

n2 is the new selection. The selection range is [0, 8]. If n2 is zero, the selection remains unchanged.

Example: IF,3,5 sets a new level of 3 and a new selection of 5.

Response: "OK"

Stored Parameter List (SPL)

Below is a table of stored parameters followed by descriptions of each parameter.

Index	Description	Range of Values	Factory Setting	Meaning
1	Auto Level	0 – 1	1	disabled - enabled
2	Auto Selection - Knob Push & Turn	0 – 1	1	disabled - enabled
3	Auto Lock	0 – 1	1	disabled - enabled
4	Baud Rate	0 – 4	2	0 = 9600, 1 = 19200, 2 = 38400, 3 = 57600, 4 = 115200
5	RW 485 Transmit Delay	2 – 200	10	2 - 200 ms
6	Maximum Number of Selections	1 – 8	8	1 – 8 Selections, ignored if SPL 2 & 9 disabled.
7	Knob Push & Turn Selection Roll	0 – 1	0	disabled - enabled
8	Knob Push & Turn Update on Release	0 – 1	1	disabled - enabled
9	Auto Selection - Knob Bump	0 – 1	0	disabled - enabled
10	Knob Bump Update Timer	0 – 5	3	0 - 5 seconds, ignored if SPL 9 disabled.

Parameter Descriptions

1. Auto Level configuration affects the result of turning the encoder. Turning the encoder without pushing it in updates the command state to an Encoder Left for a counter clockwise turn or an Encoder Right for a clockwise turn unless the device is locked. If Auto Level is enabled (a value of 1), the level is updated and indicated by the encoder LED as well. The Auto Level configuration also affects the Encoder Input Commands IS and ISR. See Encoder Input Commands section for details.
2. Auto Selection - Knob Push & Turn configuration affects the result of turning the encoder while it is pushed in. Turning the encoder while pushing it in updates the command state to a Selection Left for a counter clockwise turn or a Selection Right for a clockwise turn unless the device is locked. If Auto Selection is enabled (a value of 1), the selection is updated and indicated by the column of LEDs as well. The configuration of this parameter also affects the Encoder Input Commands IS and ISR. See Encoder Input Commands section for details.
3. Auto Lock configuration affects the operation of the device when the lock input is shorted to -V. If the device is configured for Auto Lock (a value of 1) and the Lock input is shorted to -V, the encoder is locked out regardless of the software lock status (see ILK command). If the device is not configured for Auto Lock (a value of 0), the Lock input is ignored and the encoder's lock state is defined by the software lock status.
4. This parameter sets the baud rate of the device. When this parameter is changed via a RW 485 message, the response is sent at the current baud rate, then the baud rate is updated to the new baud rate specified by the value sent. The default setting of 38400 is required for use with Rane controllers (i.e., RPM 88/44/22). It can be restored by holding the encoder in during power-up for several seconds until the encoder LED turns on.
5. This parameter sets the minimum time in milliseconds the remote waits after receiving a RW 485 message before it transmits a response. It is recommended that this value not be changed. The default setting can be restored by holding the encoder in during power-up for several seconds until the encoder LED turns on.
6. Maximum Number of Selections configures the number of selections that can be accessed by the encoder (Knob Push & Turn and/or Knob Bump). This parameter is ignored if both parameters 2 and 9 are disabled.
7. Knob Push & Turn Selection Roll configures the action taken when the last (bottom) selection is reached and the encoder is pushed and turned. When enabled, the selection wraps around from last to first (or first to last, depending on encoder direction. This parameter is ignored if parameter 2 is disabled.
8. Knob Push & Turn Update on Release configures when the selection index is updated after the encoder is pushed in and turned. When enabled, the SR updates its selection index when the encoder is released, rather than updating each time the encoder is turned. This parameter is ignored if parameter 2 is disabled.
9. Auto Selection - Knob Bump configuration affects the result of bumping the encoder (pushing and releasing the encoder without turning). When enabled, the next selection is automatically chosen; the selection index is updated after the update timer expires. Selections automatically roll from last to first. Configuration of this parameter affects the commands IS and ISR. See Encoder Input Commands section for details.
10. Knob Bump Update Timer determines how long the remote waits before updating its selection index once the encoder is released. Setting this value to 0 updates the index instantly, with every press/release combination of the encoder. Increasing this value allows users to scroll through and preview selections without updating the index on every press. This parameter is ignored if parameter 9 is disabled.